

THE 2025 SANGAMON VALLEY PUBLIC WATER DISTRICT

WATER AND SANITARY SEWER ORDINANCE

ORDINANCE NUMBER 2025-03-25-1

Adopted: March 25th, 2025

Published: March 25th, 2025

Effective: March 25th, 2025

This ordinance has been duly published
under the provisions of 70 ILCS/0.01, Section 3705
Public Water District Act
(formerly Chapter 111 2/3 in Public Utilities Illinois Revised Statutes, Section 188) et seq.

*This page is intentionally left blank -
for two sided printing.*

OFFICIALS
OF THE
SANGAMON VALLEY PUBLIC WATER DISTRICT

Cameron Wygant
Chairman

Mark Reifsteck
Vice Chairman

Thomas Johnson
Richard Eardley
Staci Baxley
William Jones
Dustin Skillings
Trustees

Sonya Brock
Secretary, Board of Trustees

Ross Munsterman
Attorney

Terry Boyer
Donohue & Associates, Inc.
District Engineer

*This page is intentionally left blank -
for two sided printing.*

TABLE OF CONTENTS

CHAPTER 1 - GENERAL PROVISIONS	11
1.1 Definitions.....	11
1.2 Purpose of Regulations	16
1.3 Objectives of the District.....	16
1.4 Administration	17
CHAPTER 2 - RATES, CHARGES AND BILL PAYMENT	23
2.1 Rates.....	23
2.2 Water Used by District.....	27
2.3 Metered Service Unless Otherwise Approved	27
2.4 Inoperable Meters	27
2.5 Payment Procedure	27
2.6 Notice of Non-payment	27
2.7 Delinquent Accounts.....	28
2.8 Changes in Occupancy	28
2.9 Free Service.....	29
2.10 Temporary Residential Absences	29
CHAPTER 3 - WATER REGULATIONS	31
3.1 Management and Control of Water System	31
3.2 Refusal of Service	31
3.3 Liability	31
3.4 Use of Water on User's Premises.....	31
3.5 Specified Uses of Water	31
3.6 Damage to District Property and Unlawful Interference with Utility Service.....	32
3.7 Application for Service.....	32
3.8 Initial Charges and Permit	32
3.9 Use of Public Water Supply Required	33
3.10 District's Responsibility and Liability	34
3.11 User Responsibility.....	34
3.12 Water Meter Rental Program	36
3.13 Cross-Connection Control Requirements	36
3.14 Minimum and Maximum Setback Zone Requirements.....	37
3.15 Water Use Restrictions	37

CHAPTER 4 - WASTEWATER REGULATIONS..... 41

4.1 Management and Control of Wastewater System.....41

4.2 Refusal of Service41

4.3 Application for Service.....41

4.4 Initial Charges and Permit41

4.5 Use of Public Sewers Required42

4.6 District's Responsibility and Liability.....43

4.7 User's Responsibility.....43

4.8 Discharges into Public Sewers46

CHAPTER 5 - EXTENSION OF WATER MAINS AND SEWERS 51

5.1 Requirements for Extension51

5.2 Plan Approval Procedures51

5.3 Construction Standards.....53

5.4 Deviations from Standards.....54

5.5 Construction Observation54

5.6 Acceptance of District Extensions54

5.7 Record Drawings.....55

5.8 Maintenance Bond55

CHAPTER 6 - CONSTRUCTION REQUIREMENTS FOR WATER DISTRIBUTION SYSTEM 57

6.1 Design Criteria.....57

6.2 Materials.....61

6.3 Construction Standards.....64

6.4 Horizontal Direction Drilling Requirements65

CHAPTER 7 - CONSTRUCTION REQUIREMENTS FOR SANITARY SEWER SYSTEM..... 69

7.1 Design Criteria.....69

7.2 Sewage Pumping Stations72

7.3 Construction Standards.....74

7.4 Television Inspection76

CHAPTER 8 - PENALTY FOR VIOLATION 77

8.1 Designated77

8.2 Illegal Connections to District Sanitary Sewer System.....77

CHAPTER 9 - SEVERABILITY-PUBLICATION-EFFECTIVE DATE 79

9.1 Severability79

9.2 Publication 79

9.3 Effective Date..... 79

APPENDIX 81

Detail “A” – Water Service Connection Detail 81

Detail “B” – Sanitary Service Connection Detail..... 82

Detail “C” – Water Meter Installation Detail 83

Detail “D” – Typical Manhole Detail..... 84

Detail “E” – Typical Fire Hydrant Detail..... 85

Detail “F” – Typical Water Valve Box Detail..... 86

Detail “G” – Typical Inside Drop Connection Detail..... 87

Detail “H” – Typical Post Hydrant Detail 88

Detail “I” – Water Main Joint Restraint Detail 89

Detail “J” – Recommended Scope of Work for Professional Services Organizations..... 90

*This page is intentionally left blank -
for two sided printing.*

**SANGAMON VALLEY PUBLIC WATER DISTRICT
ORDINANCE NO. 2023-04-24-1**

AN ORDINANCE establishing and revising rules, rates, procedures, regulations and standards for the operation of the Sangamon Valley Public Water District in Champaign County, Illinois.

BE IT ORDAINED by the Chairman and Board of Trustees of the SANGAMON VALLEY PUBLIC WATER DISTRICT as follows:

Section 1 - Identification: This Ordinance shall be known as the 2023 Replacement Water and Sanitary Sewer Ordinance for the Sangamon Valley Public Water District and may be cited as the "Water and Sanitary Sewer Ordinance of 2023."

Section 2 - Severability: If any section, paragraph, clause or provision of this Ordinance is invalid, the invalidity of such section, paragraph, clause or provision shall not affect any of the other provisions of this Ordinance.

Section 3 - Repealer: All ordinances, resolutions, orders, or parts thereof, which conflict with the provisions of this Ordinance, to the extent of such conflict, are hereby repealed.

This Ordinance shall refer only to the commission or omission of acts within the territorial limits of the Sangamon Valley Public Water District now in force or from time to time altered.

PASSED this 24th day of April, 2023.

Attest:

Meghan Hennesy, Chairman

Sonya Brock, Secretary

VOTING YES:

VOTING NO:

NOT VOTING:

*This page is intentionally left blank -
for two sided printing.*

CHAPTER 1 - GENERAL PROVISIONS

1.1 Definitions

1.1.1 Water

District - The word "District", whenever the same appears herein, means Sangamon Valley Public Water District.

"Executive Administrator" shall mean the designated Chairman of the Board or their authorized deputy agent, or representative. This will typically be the Vice-Chairman of the Board.

"GM" shall mean the General Manager of the District or the authorized deputy agent, or representative of the General Manager.

"Professional services organization" shall mean a firm contracted by the Board to oversee the operations, maintenance, and management of the provision of water and wastewater services.

"General management" shall refer to either the General Manager or the Project Manager from a Professional Services Organization contracted with the District.

Main - The word "main", whenever the same appears herein, means the supply pipe, located in the public highway and/or easement, and owned and maintained by the District, to which water service connections are attached to supply water service to a premise.

Meter - The word "meter", whenever the same appears herein, means a mechanical device which measures and registers the quantity of water supplied to a customer. The meter shall be installed, owned, maintained and repaired by the user.

Multi-family Users - Mobile home parks, multifamily housing units, and apartments are those metered structures or buildings which are used for residential purposes by more than one family. This classification of user shall be served by one water meter and shall use a minimum of 20,000 gallons per month.

"OSHA" means the federal Occupational Safety and Health Administration.

"Outdoor Usage" means all water usage that does not pass through the customer's water meter that is being provided for the purposes of indoor water usage. Outdoor usage is further defined as usage that does not result in the production of wastewater that passes into the customer's waste plumbing system and therefore, does not pass into the District's sanitary system. Typical outdoor usages include water used to fill swimming pools and water gardens, water for lawn irrigation systems and garden irrigation systems, as well as bulk water sales. Indoor water usage is defined to include outside hose bibs, since said devices are normally connected to indoor

plumbing and the water passing through said devices is metered through the normal water meter, but whose usage does not typically result in the production of wastewater.

"Person" shall mean any individual, firm, company, association, society, corporation, or group.

Residential users - (residential owners and/or his authorized agent and renters, including but not limited to mobile home owners and renters, apartment owners and renters), are those metered structures or buildings which are used for residential purpose by a single family only. Commercial users using less than 20,000 gallons per month shall be considered for rate purposes as Residential users.

User - The word "User", whenever the same appears herein, means the person or party having sole interest in any premises which is, or is about to be, supplied with water service and/or wastewater service by the District, and the word "Owner(s)" means all so interested. A contract purchaser shall not be deemed the owner of a premises.

Water Service Connection - means a pipe, with appurtenances, used to conduct water from the main to the premises to be served. The connection, pipe and all appurtenances required as part of this installation shall be installed and maintained by the user.

1.1.2 Wastewater

"BOD" (denoting Biochemical Oxygen Demand) shall mean the quantity of oxygen utilized in the Biochemical oxidation of organic matter under standard laboratory procedure in five (5) days at 20 degrees C, expressed in milligrams per liter.

"Building Drain" shall mean that part of the lowest horizontal piping of a drainage system which Receives discharge from soil, waste, and other drainage pipes inside the walls of the building and conveys it to the building sewer, beginning five (5) feet (1.5 meters) outside the inner face of the building wall.

"Building Sewer" shall mean the extension from the building drain to the public sewer or other place of disposal.

"Combined Sewer" shall mean a sewer which is designed and intended to receive wastewater, storm, surface, and groundwater drainage. (Sewers of this type shall not be permitted within the District).

"Control Manhole" shall mean a structure located on a site from which industrial wastes are discharged. Where feasible, the manhole shall have an interior drop. The purpose of a "control manhole" is to provide access for the District representative to sample and/or measure discharges.

District - The word "District", whenever the same appears herein, means Sangamon Valley Public Water District.

"Effluent Criteria" are defined in any applicable "NPDES Permit".

"Executive Administrator" shall mean the designated Chairman of the Board or their authorized deputy agent, or representative. This will typically be the Vice-Chairman of the Board.

"Floatable Oil" is oil, fat, or grease in a physical state such that it will separate by gravity from wastewater by treatment in an approved pre-treatment facility. Wastewater shall be considered free of floatable fat if it is properly pre-treated and the wastewater does not interfere with the collection system.

"Garbage" shall mean solid wastes from the domestic and commercial preparation, cooking, and dispensing of food, and from the handling, storage, and sale of produce.

"GM" shall mean the General Manager of the District or their authorized deputy agent, or representative.

"Professional services organization" shall mean a firm contracted by the Board to oversee the operations, maintenance, and management of the provision of water and wastewater services.

"General management" shall refer to either the General Manager or the Project Manager from a Professional Services Organization contracted with the District.

"Industrial Waste" shall mean any solid, liquid, or gaseous substance discharged, permitted to flow or escaping from any industrial, manufacturing, commercial or business establishment or process from the development, recovery, or processing of any natural resource as distinct from sanitary sewage.

"Multi-family Users" are mobile home parks, multifamily housing units, and apartments which are those metered structures or buildings used for residential purposes by more than one family. This classification of user shall be served by one water meter and shall use a minimum of 20,000 gallons per month.

"Natural Outlet" shall mean any outlet into a watercourse, pond, ditch, lake, or other body of surface or groundwater.

"pH" shall mean the logarithm (base 10) of the reciprocal of the hydrogen-ion concentration expressed by one of the procedures outlined in "Standard Methods".

"Permanent Easement" shall mean an acquired perpetual legal right for the specific use of land owned by others.

"Person" shall mean any individual, firm, company, association, society, corporation, or group.

"Population Equivalent" is a term used to evaluate the impact of industrial or other waste on a treatment works or stream. One population equivalent is 100 gallons of sewage per day,

containing 0.17 pounds of BOD and 0.22 pounds of suspended solids.

"Pre-treatment" shall mean the treatment of wastewater from sources before introduction into the wastewater treatment works.

"Properly Shredded Garbage" shall mean the wastes from the preparation, cooking, and dispensing of food that have been shredded to such a degree that all particles will be carried freely under the flow conditions normally prevailing in public sewers, with no particle greater than one-half (1/2) inch (1.27 centimeters) in any dimension.

"Public Sewer" shall mean a sewer in which all owners of abutting properties have equal rights, and is controlled by the District.

"OSHA" means the federal Occupational Safety and Health Administration.

Residential users - (residential owners and/or his authorized agent and renters, including but not limited to mobile home owners and renters, apartment owners and renters), are those metered Structures or buildings which are used for residential purpose by a single family only. Commercial users using less than 20,000 gallons per month shall be considered for rate purposes as Residential users.

Sanitary Sewer" shall mean a sewer that conveys sewage or industrial wastes or a combination of both, and into which storm, surface, and ground waters or unpolluted industrial wastes are not intentionally admitted.

"SCADA" is an acronym that stands for Supervisory Control and Data Acquisition system. SCADA shall mean a control system architecture that uses computers, networked data communications and graphical user interfaces for high-level process supervisory management, but uses other peripheral devices such as programmable logic controllers and discrete PID controllers to interface to the processes, pumps and other machinery.

"Sewage" is used interchangeably with "wastewater".

"Sewer" shall mean a pipe or conduit for conveying sewage or any other waste liquids, including Storm, surface, and groundwater drainage.

"Slug" shall mean any discharge of water, sewage, or industrial waste, which in concentration of any given constituent or in quantity of flow exceeds for any period of duration longer than fifteen (15) minutes more than five (5) times the average twenty-four (24) hour concentration of flows during normal operation.

"Storm Water Runoff" shall mean that portion of the precipitation that is drained into the sewers. "Storm Sewer" shall mean a sewer that carries storm, surface, and ground water drainage but excludes sewage and industrial wastes other than unpolluted cooling water.

"Suspended Solids" shall mean solids that either float on the surface of, or are in suspension in water, sewage, or industrial waste, and which are removable by a laboratory filtration device.

Quantitative determination of suspended solids shall be made in accordance with procedures set forth in "Standard Methods".

User - The word "User", whenever the same appears herein, means the person or party having sole interest in any premises which is, or is about to be, supplied with water service and/or wastewater service by the District, and the word "Owner(s)" means all so interested. A contract purchaser shall not be deemed the owner of a premises.

"Wastewater" shall mean the spent water of a community. From this standpoint, of course, it may be a combination of the liquid and water-carried wastes from residences, commercial buildings, industrial plants, and institutions, together with any groundwater, surface water, and storm water that may be present.

"Wastewater Facilities" shall mean the structures, equipment, and processes required to collect, carry away, and treat domestic and industrial wastes and transport effluent to a watercourse.

"Wastewater Treatment Works" shall mean an arrangement of devices and structures for treating wastewater, industrial wastes, and sludge. Sometimes used as synonymous with "waste treatment plant" or "pollution control plant".

"Water Course" shall mean a channel in which a flow of water occurs, either continuously or intermittently.

"Water Quality Standards" are defined in the Water Pollution Regulations of Illinois as issued by the Illinois Pollution Control Board, 35 Ill. Adm. Code, Part 302.

1.1.3 Land Development

"Develop" shall mean the act of changing a tract of land after its function has been altered by man, including, but not limited to, construction of structures on the land and alterations to the land - except that grading that does not alter the natural flow of storm water shall not be considered development.

"Developer" shall mean any person, firm, corporation, or other legal entity whose intent is to improve land in accordance with the regulations of the Sangamon Valley Public Water District.

"Development Agreement" shall mean a contract or agreement entered into between the owner of a property and the District, which involves a commitment by the owner to contribute funds, efforts, or other resources towards the study of the feasibility and/or the actual construction of extensions of sanitary sewers, water mains, storm sewers, street improvement, or other infrastructure improvements needed or desired for the development of the owner's property. It is generally intended that a development agreement, if deemed necessary, be entered into during the Area General Plan stage of the development approval process.

District - The word "District", whenever the same appears herein, means Sangamon Valley Public Water District.

"District Engineer" means a professional engineer, registered as such and licensed to practice in the State of Illinois, and employed as an individual or via a private firm by the Board of Trustees of the District, to provide technical expertise and counsel concerning subdivision and development matters.

"Permanent Easement" shall mean an acquired perpetual legal right for the specific use of land owned by others.

"Person" shall mean any individual, firm, company, association, society, corporation, or group.

"Record Drawings" shall mean a set of revised drawings submitted by a developer or contractor upon completion of a particular project. Said drawings reflect all changes made in the water and wastewater related components made during the construction process. Said drawings and show the exact recorded dimensions, project geometry, shop drawing changes, field changes, design changes, materials changes, major and minor modifications, and location of the water and wastewater related elements of the work completed under the contract. The term "Record Drawings" is not interchangeable with the term "As-Built" drawings. The term "As-Built" drawings reflect changes only made by the construction contractor, whereas "Record Drawings" shall include contractor changes during construction plus the design changes made by the design engineer of record.

1.2 Purpose of Regulations

This Ordinance is designed to provide rules and regulations governing the operations of the Sangamon Valley Public Water District, to the extent that such provisions may be applicable. It is further intended to govern areas, which may become a part of the District. This Ordinance is intended to promote the public health, safety, comfort and welfare of persons served by the District, and to provide for the orderly growth and harmonious development of the Sangamon Valley Public Water District.

1.3 Objectives of the District

The Sangamon Valley Public Water District is organized under the provisions of 70 ILCS/0.01, Section 3705 Public Water District Act (formerly Chapter 111 2/3 in Public Utilities Illinois Revised Statutes, Section 188) et seq. It is intended to provide adequate water service, fire protection, water treatment and supply, wastewater collection and wastewater treatment.

1.4 Administration

1.4.1 Board of Trustees

- A. A Board of Trustees is provided for under 70 ILCS, Section 3705/4 which provides, among other things, that a Board, consisting of seven (7) members, has complete control and management of the affairs of business of the Public Water District. The Board shall appoint annually a Secretary and Treasurer in accordance with the law.

Trustees shall be elected as provided in 70 ILCS 3705/4.2 and shall be compensated at a maximum rate of \$1,200.00 per year.

1.4.2 Chairman of the Board

The Board shall annually select a Chairman from among the trustees who shall serve as Executive Administrator of the District. The Chairman shall represent the District as deemed appropriate by a majority of the Board. The Chairman's duties shall include but are not limited to:

- A. To conduct and prepare the agenda for the monthly meetings.
B. To incur District obligations as required by necessity without prior Board of Trustees approval not to exceed Twenty Thousand Dollars (\$20,000.00) for any transaction. The Chairman may incur District obligations in excess of this amount for emergency operational situations and expenditures previously approved by the Board of Trustees or otherwise included in line items of the District budget.
C. To represent and serve as liaison between the District and other public agencies.
D. To administer the business of the users, and fulfill the mission of the District as directed by the Board.

The Chairman shall be compensated a maximum rate of \$1,500.00 per year.

A Vice-Chairman shall also be selected annually by the Board to conduct monthly board meetings when the Chairman is not present.

1.4.3 Utility Management

The District shall adopt either a professional services organization model or a general manager model of management.

1.4.3.1 Professional Services Organization Form of Utility Management

The District may employ a Professional Services Organization to provide full operations, maintenance, and management services and to administer the day-to-day business of the District. The Board of Trustees shall follow professional services procurement rules and regulations consistent with the conventional procedures for such procurement through a public advertisement for such services. The Board of Trustees shall select the most responsive, responsible firm to negotiate and execute a contract with for these services. In the event that the Board cannot negotiate an acceptable contract with the first selected firm, they will repeat the process with the next best respondent and so on. Appendix Item-J contains a recommended statement of qualifications for Professional Services Organizations that includes duties for such services.

The Professional Services Organization will provide an appropriately licenced operator in charge of the water and wastewater treatment plants, water distribution system and wastewater collection. Additionally, they will supervise and administer all functions and operations of the District in accordance with the laws of the State of Illinois and the specific terms as outlined in the contract.

The General management shall have the power to order all work stopped on construction, alteration or repair, replacement or connection on water mains, water service lines, sanitary sewers, sanitary service lines, or any work on the public right-of-way in the District boundaries, when such work is deemed by the General Management as being executed in violation of any ordinance relating hereto. Work shall not be resumed after the issuance of the stop work order except upon the written permission of the General Management. If the stop work order is oral, it shall be followed by a written stop work order within a reasonable period of time.

The appeals process is as follows:

1. Any user or permittee may appeal to the Board Chairman the decision of the General Management, regarding the Stop Work Order. Such appeal shall be in writing, setting forth the reasons for the appeal and shall be filed with the District Clerk within ten (10) consecutive calendar days after the receipt of the notice to Stop Work or such appeal shall be deemed waived.
2. Upon receipt of the notice, the Board Chairman shall fix a time and place for a hearing the appeal. The hearing shall be held not more than twenty (20) consecutive calendar days following the receipt of the notice of appeal by the District Clerk.
3. The filing of an appeal by the permittee shall not operate as a stay of this determination of the General Management to stop work.

As determined by the Board of Trustees, certain duties and responsibilities listed under “1.4.2.2. General Management Form of Utility Management” for the GM may be included in the scope of work for Professional services organization as appropriate.

1.4.2.2 General Manager Form of Utility Management

The District may employ a full-time GM to administer the day-to-day business of the District. The Board of Trustees shall establish the rate of compensation and benefits paid to the GM. The GM shall have the following areas of responsibility and conditions of employment:

- A. Responsible operator in charge for the water and wastewater treatment plants, water distribution system and wastewater collection system.

- B. To provide centralization of responsibility for insuring the execution of the District's mission of service to the public.
- C. To relieve the Board of Trustees of supervisory administration and operational details and permit it to more effectively concentrate its efforts on matters of District policy.
- D. To supervise and administer all functions and operations of the District in accordance with the laws of the State of Illinois and the policies of the Board of Trustees and to act as general agent of the Board in carrying out the public service mission of the District.
- E. GM shall devote the time and effort to the duties for the District and shall not, unless the same is agreed to in writing by the Board, be directly or indirectly involved in any type of business. This section shall not prohibit the General Manager from being a non-working investor in any type of business.
- F. To sign checks and fiscal documents prepared by the Treasurer, Secretary, and other District officials.
- G. To employ, supervise, discharge, and recommend the compensation of any and all District employees and to establish the duties and conditions of employment for said employees.
- H. To prepare the budget for approval by the Board of Trustees and insure the solvent fiscal operation of the District.
- I. To incur District obligation as required by necessity without prior Board of Trustees approval not to exceed Seven Thousand, Five Hundred and 00/100ths Dollars (\$7,500.00) for any transaction except for emergency operational situations and expenditures prospectively approved as included in line items of the District budget authorized by the Board of Trustees.
- J. To exercise custodianship of negotiable instruments, stocks, bond contracts, and similar documents owned by the District.
- K. To establish and disestablish accounts with financial institutions as deemed necessary.
- L. To negotiate user contracts with prospective customers of the District.
- M. To negotiate loans, grants, permits, and related matters with the appropriate local, state and federal governments or governmental agencies. Included in such duties includes signing Illinois EPA loan documents, including loan disbursement requests.

- N. To negotiate with other professional groups such as engineers and surveyors for professional service contracts.
- O. To negotiate with general and subcontractors for the performance of work to be done for the District.
- P. To direct their time and efforts to both the administrative duties of the District and operation and maintenance of the water and wastewater systems.
- Q. To expeditiously pursue with the state and/or educational institutions a certificate or certificates wherein they are recognized as an authorized wastewater and water operator. The GM shall attend any and all classes and take any and all courses which they feel are necessary to accomplish the same.
- R. To keep the Board of Trustees fully and completely advised of his acts and dealings at all reasonable times.
- S. Within one (1) year from the initial date of employment, to move to a place of personal permanent residency within twenty-five (25) straight line miles of the nearest edge of the District's territorial limits as they exist at the time of initiation of; or provided, however, for good cause shown, such time may on mutual written agreement of the parties be extended from time to time.
- T. To perform and exercise such other powers and duties as may be conferred upon them by resolution of the Board of Trustees of the District.
- U. Stop work orders

The General Manager shall have the power to order all work stopped on construction, alteration or repair, replacement or connection on water mains, water service lines, sanitary sewers, sanitary service lines, or any work on the public right-of-way in the District boundaries, when such work is deemed by the General Manager as being executed in violation of any ordinance relating hereto. Work shall not be resumed after the issuance of the stop work order except upon the written permission of the General Manager. If the stop work order is oral, it shall be followed by a written stop work order within a reasonable period of time.

The appeals process is as follows:

1. Any user or permittee may appeal to the Board Chairman the decision of the General Manager, regarding the Stop Work Order. Such appeal shall be in writing, setting forth the reasons for the appeal and shall be filed with the District Clerk within ten (10) consecutive calendar days after the receipt of the notice to Stop Work or such appeal shall be deemed waived.

2. Upon receipt of the notice, the Board Chairman shall fix a time and place for a hearing the appeal. The hearing shall be held not more than twenty (20) consecutive calendar days following the receipt of the notice of appeal by the District Clerk.
3. The filing of an appeal by the permittee shall not operate as a stay of this determination of the General Manager to stop work.

1.4.3 Records and Accounts

- 1.4.3.1 The District Treasurer shall establish a proper system of accounts and shall keep proper books, records, and accounts in which complete and correct entries shall be made of all transactions relative to the water and wastewater systems. At regular annual intervals they shall order an audit to be made by an independent auditing concern of the books to show the receipts and disbursements of the water and waste water systems funds.
- 1.4.3.2 The Illinois Environmental Protection Agency or its authorized representative shall have access to any books, audit reports, documents, papers, and records of the District which are applicable to the District system of user charges or industrial cost recovery for the purpose of making any audit, examination, excerpt, and transcription thereof to insure compliance with the terms of the special and general conditions to any state grant or loan.

1.4.4 Annual Audit Report

- 1.4.4.1 In addition to the customary operating statements, the annual audit report no later than One hundred eighty (180) consecutive calendar days after close of the fiscal year shall also reflect the revenues and operating expenses of the water and wastewater facilities. The financial information to be shown in the audit report shall include the following:
 - A. Flow data showing total gallons received at the wastewater plant for the current fiscal year.
 - B. Flow data showing total gallons pumped from the water treatment plant. Total gallons and purpose of any water not delivered to meters. Billing data to show total number of gallons billed.
 - C. Debt service for the next succeeding fiscal year.
 - D. Number and classification of users connected to the system.
 - E. Number and classification of non-metered users.
 - F. A list of users discharging non-domestic wastes (industrial users) and volume of waste discharged.

1.4.5 Copy of Regulations, Claims

- 1.4.5.1 A copy of these regulations properly certified by the District Secretary, shall be filed in the office of the County Recorder of Deeds and shall be deemed notice to all owners of real estate of their liability for service supplied to any users of the service of the water and wastewater system of the District on their properties. It shall be the duty of the Secretary and the Board of Trustees to take all action necessary or required by the laws of the state to file all claims for money due to the District and to prosecute and enforce these claims in the manner, form, and time permitted by the laws of the state.

END OF CHAPTER 1

*This page is intentionally left blank -
for two sided printing.*

CHAPTER 2 - RATES, CHARGES AND BILL PAYMENT

2.1 Rates

2.1.1 Water Rates - Residential Users – Inside the District (Indoor Usage)

A. Quantity/Month: The water usage charge shall consist of the Minimum Charge plus the Consumption charge described as follows:

1. Minimum Charge: Each Residential User shall be charged the following each month:

The first 2,000 gallons of metered water or any fraction thereof = \$19.55

2. Consumption Charge: All consumption thereafter is \$6.60 per thousand gallons or any fraction thereof. The minimum amount shall be 2,000 gallons per month on a single meter.

2.1.2 Water Rates - Residential Users - Inside the District (Outdoor Usage Only)

A. Quantity/Month: Each Residential User shall be charged the following each month:

1. All Outdoor Water Usage is \$7.15 per thousand gallons or any fraction thereof.

2.1.3 Water Rates - Residential Users – Outside District Boundaries (Indoor Usage)

A. Customers outside the District Boundaries are charged 25% over in-District customers. Quantity/Month: The water usage charge shall consist of the Minimum Charge plus the Consumption charge described as follows:

1. Each Residential User shall be charged the following each month:

The first 2,000 gallons of metered water or any fraction thereof = \$24.44.

2. All consumption thereafter is \$8.25 per thousand gallons or any fraction thereof. The minimum amount shall be 2,000 gallons per month on a single meter.

2.1.4 Water Rates – Residential Users – Outside District Boundaries (Outdoor Usage)

A. Customers outside the District Boundaries are charged 25% over in-District customers. Quantity/Month: Each Residential User shall be charged the following each month:

1. All outside water usage will be \$8.94 per thousand gallons (secondary meter)

2.1.5 Water Rates - Multifamily Users/Commercial (Indoor Usage)

A. Quantity/Month: The water usage charge shall consist of the Minimum Charge plus the Consumption charge described as follows:

1. Minimum Charge: Each Multi-family and Commercial User shall be charged the following each month:

The first 2,000 gallons of metered water or any fraction thereof = \$19.55

2. Consumption Charge: All consumption thereafter is \$6.60 per thousand gallons or any fraction thereof.

2.1.6 Water Rates - Multifamily Users/Commercial/Bulk Sales (Outdoor Usage)

A. Quantity/Month: Each Multi-Family User/Commercial/Bulk Sale User shall be charged the following each month:

1. All Outdoor Water Usage is \$7.15 per thousand gallons or any fraction thereof.

2.1.7 Wastewater Users - All Users

A. Quantity/Month: The wastewater user charge shall consist of the Minimum Charge plus the Metered charge described as follows:

1. Each User shall be charged the following each month as metered by the water meter on the customer's water service line:
 - a. Minimum Charge: The first 2,000 gallons of metered water, or any fraction thereof = \$16.18
 - b. All consumption thereafter is \$6.60 per thousand gallons or any fraction thereof. The minimum amount shall be 2,000 gallons based on monthly, metered water usage.

2.1.8 Second Meter Required

- A. All new construction of buildings or homes of any type which are serviced with potable water from the Sangamon Valley Public Water District is required to install a separate water meter to record consumption of water for lawn watering, or related outside usage. They shall make application to the District as per the requirements for a new service. Water used for outside purposes only shall be billed as Outdoor Water consumption only, under the terms of Articles 2.1.2, 2.1.4 and 2.1.6 herein as applicable, and said usage shall be exempt from the wastewater service charge. No minimum charge for zero usage. The water meter shall be purchased from the District and installed by the user at their own expense.

2.1.9 Capacity Fees

- 2.1.9.1 Capacity Fees are a one-time charge to existing and new dwellings, industrial facilities and buildings, or commercial buildings connecting to the water or sanitary sewer system. These fees are used to reduce the economic burdens brought on by population growth in the Water District. These fees provide funding for additional capacity at the water and wastewater treatment plants, collection systems and distribution systems.

- 2.1.9.2 Any owner of existing dwelling or builder of each new residential dwelling, industrial building, or commercial building prior to connecting to the water or sanitary sewer system must apply for a permit to tap-on to the system. The District shall require all permit applicants to pay a \$800.00 per P.E. Fee (Population Equivalent) plus a new Water Access Charge in the amount of \$2,000.00. This fee is based on the P.E. 1 rating of the particular building, business or residence constructed.

- 2.1.9.3. The P.E. fees for the District will be as follows:

Table 2.1.9.3 - P.E. Fee Table

Type of Unit	P.E. Rating	P.E. Fee
New Water Service Access Charge	Not Applicable	\$1,500.00
Studio Apartment, Townhouse or Condominium	1.0	\$650.00/unit
1 Bedroom Apartment, Townhouse or Condominium	1.5	\$975.00/unit
2 Bedroom Apartment, Townhouse or Condominium	3.0	\$1,950.00/unit
3 Bedroom Apartment, Townhouse, Condominium	3.0	\$1,950.00/unit

¹ The P.E. rating is determined by the Illinois Environmental Protection Agency. One (1) P.E. is equal to 100 gallons of water used per day person.

Single Family Dwelling, up to 3 Bedrooms	3.5	\$2,275.00
Single Family Dwelling, 4 Bedrooms or more	4.0	\$2,600.00
<ul style="list-style-type: none"> • Commercial Buildings will have a minimum 3.5 P.E. rating. The P.E. Fee determined by the District Engineer at the time a water and sewer permit is issued. 		
<ul style="list-style-type: none"> • Industrial Facilities will be a minimum 3.5 P.E. rating. The P.E. Fee determined by the District Engineer at the time a water and sewer permit is issued. 		

2.1.10 Construction Cost Recovery Fees

2.1.10.1 The Construction Cost Recovery Fees are a one-time charge designed to recover the Districts cost of labor, material and engineering for the installation of water and sewer mains and any other means used to convey, pump or store water or wastewater. The Construction Cost Recovery Fees will automatically increase by 3% each calendar year on December 31st. Designated construction areas shall be determined by the District, in the District’s sole discretion and shall include, but not be limited to, Meadow Lake Subdivision, Trailside Subdivision, and South Lake of the Woods Road.

2.1.10.2 Any owner of existing dwelling or builder prior to connecting to the water or sewer must apply for a permit to tap-on to the systems. The District shall, as part of the permit process, require the owner or builder to pay a \$1,870.00 per P.E. Fee (Population Equivalent) and \$2,500 New Water Service Construction Cost Recovery Fee. The Construction Cost Recovery Fees for the District will be as follows:

Table 2.1.10.2 - Construction Cost Recovery Fee Table

Type of Unit	P.E. Rating	P.E. Fee
New Water Service Access Charge	Not Applicable	\$2,500.00
Studio Apartment, Townhouse or Condominium	1.0	\$1,870.00/unit
1 Bedroom Apartment, Townhouse or Condominium	1.5	\$2,805.00/unit
2 Bedroom Apartment, Townhouse or Condominium	3.0	\$5,610.00/unit
3 Bedroom Apartment, Townhouse, Condominium	3.0	\$5,610.00/unit
Single Family Dwelling	3.5	\$6,545.00
<ul style="list-style-type: none"> • Commercial Buildings will have a minimum 3.5 P.E. rating. The Construction Cost Recovery Fee determined by the District Engineer at the time a water and sewer permit are issued. 		
<ul style="list-style-type: none"> • Industrial Facilities will be a minimum 3.5 P.E. rating. The Construction Cost Recovery Fee determined by the District Engineer at the time a water and sewer permit is issued. 		

2.2 Water Used by District

All water used by the District exclusive of water from fire hydrants shall be metered. This includes water used in conjunction with operations at the water plant itself.

2.3 Metered Service Unless Otherwise Approved

Service for water and/or sewer shall be by meter only, subject to the approval of the Board of Trustees of the District.

2.4 Inoperable Meters

If a meter fails to provide the correct amount of consumption, then the User, upon notice by the District, shall have cause to make repairs or replace with a new meter purchased from the District. Initially, the District will estimate the consumption based upon the previous month's consumption. For each billing period after the notice, 1,000 gallons will be added to the estimated consumption until such time as the meter is operable.

2.5 Payment Procedure

Due Date: Meters will be read by the District on or about the 20th day of each month, bills will be mailed on the last day of each month, the same being due and payable on the 20th of the following month; If weather conditions or other circumstances prevent the reading of meters, then each water bill will be estimated by the District based on the average of the previous months' usage. Bills will be made payable to: "Sangamon Valley Public Water District". Bills may be paid at the office of the District, located at 709 North Prairieview Road, Mahomet, Illinois or paid at other locations as designated by the Board of Trustees. Payment may also be mailed to: P. O. Box 285, Mahomet, Illinois 61853.

Confirmed receipt of payment to the District shall void the written water service termination date.

2.6 Notice of Non-payment

There will be a ten percent (10%) penalty added to each bill that is unpaid by the due date. If any bills remain unpaid an additional 15 days, the water supply to the property affected will be shut off by the District after proper notification to the user. (For purposes of definition, "proper notification" shall be deemed to mean any conventional means of written communication). This constitutes a period of forty-five (45) consecutive calendar days from the date the bill was originally mailed. Service will not be restored until the delinquency and the penalty is paid in full. Payment of a Thirty-five Dollar (\$35.00) re-connection fee will be necessary to restore water service. The District shall charge a \$30.00 non-sufficient fund fee for bad checks, plus any additional fee(s) incurred by the district.

There will be a ten percent (10%) penalty added to each customer/vendor invoice that is unpaid after thirty (30) days for meter purchases, equipment purchases, material parts & repair, and maintenance/installation.

2.7 Delinquent Accounts

Whenever the District undertakes the collection of delinquent water and wastewater usage bills or any other delinquent charges billed to the user or property owner, the District is entitled to recover its costs of collection, including reasonable attorney's fees and expenses, court costs and any other expenses related to the collection process, and regardless of whether or not litigation was initiated for purposes of collection. The above expenses may also become lien on the real estate to which the delinquency relates, upon proper notification. (Proper notification shall be as defined in paragraph 2.6 above). Rental property delinquent accounts for the following services: water and sewer usage, late fees, reconnect cost and damages to meter are ultimately the responsibility of the property owner, should the renter vacate the premises or refuse to pay. After 90 days, a collection process will be initiated.

Should a user wish to re-activate their account after paying in full, or paying the collection agency, a \$35.00 re-activation charge will occur and said charge must be paid in full prior to reconnecting water services.

2.8 Changes in Occupancy

There shall be a \$15.00 charge for transferring the water service or sewer service to a subsequent user. Any user requesting a termination of service shall give written notice to the District ten (10) consecutive calendar days prior to the time the termination of service is desired. The meter shall be read by the District and the user will be billed. Responsibility for payment for water consumed prior to the date of termination shall be with the user at the time of service.

The property owner has final responsibility for the water and sewer bill.

2.9 Free Service

No free services of the combined water and wastewater system of the District shall be furnished to any person, firm, organization, or corporation, public or private. Every user of the District water and wastewater system shall have a metered water connection to the system, including those persons and/or firms who make temporary connections to fire hydrants for construction purposes.

2.10 Temporary Residential Absences

Those customers who vacate their principal residence for a minimum of three (3) consecutive months will, upon proper written application, be billed as follows:

- District Disconnection (at shut-off) - \$0.00 Bill for 0 gallons of usage; Reconnection fee of \$35.00 will apply upon reconnection of services.
- Personal Disconnection (inside home) – Inactive Sewer Usage Bill for 0 gallons of usage; Only charged for minimum water use rate of \$19.55.

Notification must be made to the District Office at least 30 days prior to vacating the residence. The District will only disconnect and reconnect services during a scheduled appointment during regular business hours.

Any usage over zero (0) gallons will be charged at a regular monthly rate.

END OF CHAPTER 2

*This page is intentionally left blank -
for two sided printing.*

CHAPTER 3 - WATER REGULATIONS

3.1 Management and Control of Water System

The Sangamon Valley Public Water District, hereinafter referred to as the District, shall have the supervision, management, control, maintenance, enlargement, and operation of the water works system; all matters and things connected with the operation, maintenance, and extension of the water works system, and the selling of water therefrom and preserving the property belonging thereto, subject to the Board of Trustees of the District.

3.2 Refusal of Service

The District may, at any time, refuse additional service(s) to any applicant if, in the judgment of the Board of Trustees, the capacity of the system will not permit such use or after a public hearing, wherein the applicant may present his position to the Board, in the judgment of the Board of Trustees such refusal shall be deemed to be in the best interest of the customers of the District.

3.3 Liability

All water mains supplied by the District shall be upon the express condition that the District shall not be liable nor shall any claim be made against it for damages or injury caused by reason of shutting off of water for repair, relocation, or expansion of any part of the system, or failure of any part of the system or for concentration of water for such purposes as fire-fighting or restricted use of water.

3.4 Use of Water on User's Premises

The District shall reserve the right to use the water from the user's facilities at any time deemed necessary. Such water usage could include, but not be limited to, any usage necessary for the repair or maintenance of the District system. No charge shall be made by the user for the use of their facilities and no charge shall be made by the District for the water used by the District.

3.5 Specified Uses of Water

Water purchased from the District may be used for ordinary domestic, commercial, or industrial use upon the premises of the user provided:

- A. No user shall resell or permit the resale of water purchased from the District.

- B. All standalone buildings shall have separate cut-off valve, meters and service line installed for each unit.
- C. Trailer parks and multi-building apartment complexes may be served through one master meter and the bill shall be computed on a volume basis.

3.6 Damage to District Property and Unlawful Interference with Utility Service

Unlawful interference with utility services: A person commits the offense of violating this ordinance when that person knowingly, without the consent of the District, impairs or interrupts any water supply or diverts, or causes to be diverted in whole or in part, any water supply, or installs or removes any device for the purpose of such diversion or in any way impairs or attempts to alter meters or meter reading devices.

The penalty for a person who tampers, damages, adjusts, or in any manner interferes with the components or operation of the system, shall be One Thousand Dollars (\$1000.00), payable to the District. In addition to the penalty, the user responsible shall reimburse the District for the cost of repairing damage resulting for the user's act. Each day of violation shall be a continuing offense.

Users shall report any known evidence of tampering, adjusting, damaging, or interference with operation of the system, owned by the District, to the General Management. Any malicious act or damage to the system that is not appropriately punishable by the foregoing shall be prosecuted through a court of law.

3.7 Application for Service

Water supply shall be furnished only to District users upon filing of an application and water users' agreement (where required) with the General Management of the District upon a form to be supplied by the District. The contract thus formed between the District and the user shall be deemed a covenant running with the land which shall be binding on subsequent owners, grantees, assignees, and successors, with the same force and effect as exists between the original parties thereto.

3.8 Initial Charges and Permit

The following procedure shall be followed when a customer, builder, or developer desires to tap-in to a public water main for water service:

- A. Water Service
 - 1. Prior to service installation, a tap-on permit shall be acquired from the District office; said permit shall be accompanied by a Thirty-Five Dollar (\$35.00) inspection fee for the water service, plus a deposit of Five Hundred Dollars (\$500.00). Said deposit to be

returned without interest, upon final inspection of the completed installation. If any assessment for water service is due, it shall also be paid at this time.

2. Tap-on to an existing water main shall be accomplished only in the presence of/or by a Sangamon Valley Public Water District operator.
3. Any tap-on in violation of the above procedure shall entail a Two-Thousand Five Hundred Dollars (\$2,500.00) penalty to be paid by the violator before service is restored. Violator may be subject to prosecution for trespassing.
4. Security Deposits
 - a. A deposit of Thirty-Seven and 50/100ths Dollars (\$37.50) shall be made by all residential renters to guarantee payment of water and/or wastewater bills. The deposit shall be returned to user without interest upon termination of water and/or wastewater service and all accounts of that user being paid.
 - b. Disconnection for delinquent payment or violation of regulations: The District will require full payment of all charges before any service is restored.

B. Plan

1. A sketch or plan shall be provided by the user showing the location of the tap, shut-off valve and location of the service line. A list of approved materials shall also be provided.
2. Upon completion of construction, corrected "As-Built" drawings shall be furnished to the District. Measurements showing "ties" from the shut-off valve to permanent topographic features shall be shown.

3.9 Use of Public Water Supply Required

The owner of all houses, buildings, or properties used for human occupancy, employment, recreation, or other purposes, situated within the District and abutting any street, alley, or right-of-way in which there is now located a public water main of the District, is hereby required at his expense to connect such facilities directly with the proper public water main in accordance with the provisions of this Ordinance, within ninety (90) days after date of official notice to do so, provided that said public water main is within one hundred (100) feet (30.5 meters) of the property line.

At such time as a public water main becomes available to a property served by a private water system, a direct connection shall be made to the public water system in compliance with this Ordinance. Any wells or other private sources of water supply shall be disconnected from

domestic use within the residence. On-site wells may be retained for purposes other than domestic use. If abandonment is necessary due to non-use, (For purposes of this ordinance, Non-use shall be defined as no use for a period of 1 year or more) such abandonment shall be inspected and approved by the appropriate state or local officials.

3.10 District's Responsibility and Liability

Ownership, Installation, and Maintenance: The District shall install, own, inspect, operate, and maintain the complete water system, water mains (exclusive of water meters, service lines, standpipes, and shutoff valves). Since the District does not own any customer service lines, it is not obligated to locate any such services, when called to locate water and sanitary sewer facilities under the Joint Utility Locating Information for Excavators (J.U.L.I.E.) system, as operated by JULIE, Inc., which by law, the District is a member.

The District may at any time refuse additional service(s) to any applicant if in the judgement of the Board of Trustees, the capacity of the system will not permit such use or the service is not economically feasible.

The District reserves the right to perform or require repair service to the user's equipment on a timely basis; the cost of said repairs shall be borne by the user. All such repairs shall be subject to final inspection by District personnel upon completion.

The District shall make available a temporary water meter and backflow preventer that may be connected to a fire hydrant to provide short-term service.

3.11 User Responsibility

The user shall furnish, install, and maintain water meters, service lines, and such valves, saddles, junctions, and/or other control devices as may be required for connection to the District's water mains. The materials used in any water installation or repair shall be only as specified herein. The installation of the water tap, service lines, and valves shall be as per Detail "A" included in the Appendix. The water meter installation shall be constructed as per Detail "C" in the Appendix.

The user shall be responsible for installation and maintenance of service lines between the District's water main and the residence or business. Such services must be at least 1-inch nominal diameter, and must be installed with a minimum depth of cover of 4 feet. Service lines must have a minimum working pressure rate of 200 psi at 73.4 degrees F and must be constructed of following type of material: SDR - 9, copper tube size polyethylene water pipe (meeting ASTM D2737). The District reserves the right to require an increased water service line size or installation of an additional water service line to the existing service line in order to provide adequate water supply to proposed water usage systems within residential or business properties. If, for example, a proposed residential property has more than 4 bedrooms or 4 bedrooms or more with a fire suppression system and/or an outside irrigation system, the

plumbing contractor shall demonstrate the calculations for sizing the water service line by use of the Illinois Plumbing Code 892-1200, prior to issuance of the water/sewer installation permit.

Service lines larger than two inches shall be PVC, SDR-21 grade (meeting ASTM D2241) and conforming to the water main line specifications as described in Section 6.2 of this document. Service lines must not be covered until they are inspected and approved by a duly authorized District representative. The user shall not connect any service line or any plumbing connected with the service line to any other water source. The service line must meet all requirements of the Illinois Environmental Protection Agency and the State of Illinois Plumbing Code, edition at the time of the service line application.

Horizontal and Vertical separation for water and sewer service lines shall meet the following requirements:

Water service lines shall be located at least ten (10) feet horizontally from any existing or proposed drain, storm sewer, sanitary sewer, or sewer service line. Placement of water service lines and sanitary sewer service lines within the same trench is not permitted.

If conditions prevent a lateral separation of ten (10) feet or if the vertical separation is less than eighteen (18) inches between the water service and the sanitary sewer service, (either above or below each other), the sewer shall be constructed of water main quality materials, i.e., slip-on or mechanical, cast or ductile iron joint pipe, or PVC pipe equivalent to water main standards of construction.

The protection of water main and water service from sanitary sewers, storm sewers, combined sewers, house service connections and drains shall meet the conditions set forth in Section 41 - 2.01 Of the Standard Specifications for Water and Sewer Construction in Illinois, the edition at the time of the service line application.

The location of the water meter and such other control devices as may be required for said installation shall be determined by General Management. The user will provide, at his or her expense, a clean, dry, safe place, not subject to a great variation in temperature so that the meter will be properly protected from freezing and other hazards, so located as to control the entire supply and as to be easily accessible for installation, maintenance, reading, and disconnection. No master water meter installation will be permitted in a residential "crawl space". The meter and all other control devices shall be as specified by the District. Meters and other materials specified as part of this type of installation are available for purchase at the District office. The meter installation shall comply with all applicable local and state building and/or plumbing codes.

Water service may not be turned on to the user's residence or place of business until a final inspection of the installation is completed by the District and the water meter and all control devices are properly installed. All outside installations of water service lines shall be inspected by District personnel prior to backfill. No inspections will be made outside of normal District working hours (8:00 AM to 4:00 PM prevailing time) or on weekends or District holidays.

The user shall give such easements and rights-of-way as necessary to the District and allow access for the purposes of construction, repair, maintenance, meter reading, relocation, or expansion of the water system. The necessity shall be determined by the Board of Trustees.

3.12 Water Meter Rental Program

Whenever a user wishes to install a separate water meter to record consumption of water for lawn sprinkling, or related outside usage, they shall make application to the District as per the requirements for a new service. Water used for outside purposes only shall be billed as water consumption only, and shall be exempt from the wastewater service charge. This second meter will be billed for water used only. No minimum charge for zero usage (during winter months). The permanent meter shall be purchased from the District and installed by the user at the user's own expense. For temporary water uses such as filling swimming pools or summer time yard uses arrangements may be made with the District Office for meter rental.

3.13 Cross-Connection Control Requirements

If, in accordance with the Illinois Plumbing Code or in the judgement of the General management, an approved back-flow prevention device is necessary for the safety of the public water supply system, the General management will give notice to the water customer to install such an approved device immediately. The water customer shall, at his own expense, install such an approved device at a location and in a manner in accordance with the Illinois Plumbing Code and all applicable local regulations, and shall have inspections and tests made of the approved devices as required by the Illinois Plumbing Code and local regulations.

No person, firm, or corporation shall establish or permit to be established, or maintain or permit to be maintained, any connection whereby a private, auxiliary, or emergency water supply other than the regular public water supply of the District may enter the supply or distribution system of the District, unless that private, auxiliary, or emergency water supply and the method of connection and use of the supply shall have been approved by the General management and the Illinois Environmental Protection Agency.

It shall be the duty of the General management to cause surveys and investigations to be made of industrial and other properties served by the District to determine whether actual or potential hazard to the public water supply may exist. These surveys and investigations shall be made a matter of public record, and shall be repeated at least every two years, or as often as the General management shall deem necessary. Records of the surveys shall be maintained and available for review for a period of at least five (5) years.

The approved cross-connection control device inspector shall have the right to enter at any reasonable time any property served by a connection to the District for the purpose of verifying the presence or absence of cross-connections. The General management or the GM's authorized agent shall have the right to enter at any reasonable time any property served by a connection

to the District for the purpose of verifying information submitted by the customer regarding the required cross-connection control inspection. On demand, the owner, lessees, or occupants of any property so served shall furnish to the General management any information that the General management may request regarding the piping system or systems or water use on the property.

The refusal of such information, when demanded, shall, within the discretion of the General management, be deemed evidence of the presence of improper connections as provided in this section.

The General management is authorized and directed to discontinue, after reasonable notice to the occupant thereof, the water service to any property wherein any connection in violation of the provisions of this section is known to exist, and to take such other precautionary measures as he may deem necessary to eliminate any danger of contamination of the District water supply distribution mains. Water service to that property shall not be restored until those conditions have been eliminated or corrected in compliance with the provisions of this section. The user responsible for back-siphoned material or contamination through back-flow, if contamination of the potable water supply system occurs through an illegal cross-connection or an improperly installed, maintained, or repaired device, or a device which has been by-passed, must bear the cost of clean-up of the potable District Water Supply System.

3.14 Minimum and Maximum Setback Zone Requirements

Except as provided for by the Illinois Groundwater Protection Act 415 ILCS 55/i, et. seq (1992 State Bar Edition), (formerly Ill. Rev. Stat. 1991, Ch. 111 1/2, Para. 7451), within this section hereinafter referred to as the "Act", no person shall place a new potential primary pollution source, new potential secondary pollution source, or new potential pollution route within the minimum setback zone of Five Hundred (500) feet of any water production well site currently operated by the Sangamon Valley Public Water District.

Except as provided for by the Act, no person shall place a new potential primary source of pollution with the maximum setback zone of One Thousand (1,000) feet of any water production well site currently operated by the Sangamon Valley Public Water District.

For purposes of definition, a pollution source or route is as defined in the Act, the text of which is incorporated in this policy by reference.

3.15 Water Use Restrictions

- A. The General management of the District may, after receiving the approval of the Board of Trustees, place restrictions on water usage by the customers of the District in any of the following situations in which it appears that unlimited usage of water could be greater than the ability of the system to provide such water or there would be a situation which would adversely affect the health or safety of the customers:

1. The water storage tower(s) and/or ground storage tank(s) are not in use because of necessary repairs or are being painted.
 2. Any source water production well is out of service for repair or other reason.
 3. For any reason, the water system is unable to maintain a pressure of 45 pounds per square inch in the system as measured at the water treatment plant at 709 North Prairieview Road.
 4. In the event of a major water main break or breaks or other system malfunctions which would affect the ability of the system to deliver water in compliance with state and/or federal regulations.
 5. In the event of a major natural or manmade disaster which would affect the ability of the system to deliver water in compliance with state and/or federal regulations.
- B. In the event any one or more of the above conditions exists, the General management of the District, with the approval of the Board of Trustees, may impose restrictions on the use of water within the District. Depending on the severity of the situation, weather conditions and anticipated length of time that such condition may continue to exist, the General management may adopt the restrictions of any of the following levels and may change the restriction level to a higher or lower level as conditions change.

Level 1: Water shall not be used from the water system for the watering of yards, gardens, shrubs, trees or/and other open spaces. Water from the system shall not be used for the initial filling of swimming pools or for the washing of houses or other buildings or for the washing of automobiles, trucks, motor homes and recreational vehicles or any other vehicles by private individuals not at a commercial car-washing establishment.

Level 2: In addition to the restrictions in Level 1, water shall not be used for replacing water in a previously filled swimming pools, and commercial car wash operations shall cease.

Level 3: In addition to the restrictions in Level 1 and Level 2, the General management shall have the authority to establish hours of water usage and the rationing of the amount of water used. Such hours and the level of rationing may be varied according to the type of water usage and the amount of water necessary for such usage.

Level 4: In addition to the restrictions in Levels 1, 2, and 3 above, water may be used only for human consumption and hygiene and all other uses of water shall cease.

- C. In the event that any person, partnership, association, corporation, business or any other entity shall violate any of the restrictions in paragraph B above, which are in effect at any time, such violator shall be given a verbal warning, followed up by a written warning, to cease the specific violation and be informed of the restrictions then in effect. After such written warning has been given, if the violation of any restrictions then in effect, continues, such violation shall be subject to a fine of One Hundred Dollars (\$100.00). Such fine shall continue to be levied at the rate of One Hundred Dollars (\$100.00) per day until such time as the violation ceases or the restriction is lifted, whichever is longer. In the case of severe or chronic and or continuing violations, the General management shall have the authority to terminate the water service of violator.

If the fines levied as a result of a violation of this section are not paid within thirty (30) days of notification of said fine, the fine will be added to the regular monthly water bill of the customer and will be subject to the regular collection procedures outlined in Section 2 of this ordinance.

END OF CHAPTER 3

*This page is intentionally left blank -
for two sided printing.*

CHAPTER 4 - WASTEWATER REGULATIONS

4.1 Management and Control of Wastewater System

The Sangamon Valley Public Water District, hereinafter referred to as the District, shall have the supervision, management, and control of the maintenance, enlargement, and operation of the wastewater system subject to the Board of Trustees of the District; all matters and things connected with the operation, maintenance, and extension of the wastewater system; and the treatment of wastewater from within the District.

4.2 Refusal of Service

The District may, at any time, refuse service(s) to any applicant if, in the judgment of the Board of Trustees, the capacity of the system will not permit such use or after a public hearing wherein the applicant may present their position to the Board, in the judgement of the Board of Trustees, such refusal is in the best interests of the customers of the District.

4.3 Application for Service

Wastewater service shall be furnished only to the District users upon filing of an application and wastewater users' agreement (both signed by the user) with the General management of the District upon a form to be supplied by the District. (May be combined with water service application) The contract thus formed between the District and the user shall be deemed a covenant running with the land which shall be binding on subsequent owners, grantees, assignees, and successors, with the same force and effect as exists between the original parties thereto.

4.4 Initial Charges and Permit

- A. Wastewater Service - No unauthorized person shall uncover, make any connections with or opening into, use, alter, or disturb any public sewer or appurtenance thereof without first obtaining a written permit from the General management. There shall be two (2) classes of permits: (1) For residential and commercial service; and (2) For service to establishments producing industrial wastes. In either case, the owner or his agent shall make application on a special form furnished by the District.

The following procedure shall be followed when a customer, builder, or developer desires to tap-on to a main servicing line:

1. Prior to service installation, a sanitary sewer tap-on permit shall be acquired from the District office; said permit shall be accompanied by a Thirty-Five Dollar (\$35.00) inspection fee. If any assessment for sewer service is due, it shall also be paid at this

time. Taps to the public sanitary sewer shall be made using only materials as specified herein and as per Detail "B" in the Appendix.

2. The actual tap-on to an existing building shall be accomplished only in the presence of a Sangamon Valley Public Water District operator.
 3. Any tap-on in violation of the above procedure shall entail a Five Hundred Dollar (\$500.00) penalty to be paid by the violator before service is restored.
 4. Security Deposits
 - a. A deposit in the amount of Thirty-Seven and 50/100ths Dollars (\$37.50) shall be made by residential renters to guarantee payment of water and/or wastewater bills. The deposit shall be returned to user without interest upon termination of water/wastewater service and all accounts of that user being paid.
 - b. In the event that water and/or wastewater service to any customer of the District is disconnected for non- payment of bills or any other violation of District ordinances, rules or regulations, the District will require full payment of all charges before service is restored.
- B. Plan - A sketch or plan shall be provided by the user detailing the location of the tap, slope, elevations, and location of the building sewer line. A list of the type of approved materials shall also be provided. Upon completion of construction, corrected "Record drawings" shall be furnished to the District.

4.5 Use of Public Sewers Required

It shall be unlawful for any person to place, deposit, or permit to be deposited in any unsanitary manner on public or private property located in an area receiving sanitary sewer service from said District, any human or animal excrement, garbage, or other objectionable waste.

In areas where sanitary sewer service is provided by the District, it shall be unlawful to discharge to any natural outlet under the jurisdiction of said District, any sewage or other polluted waters, except where suitable treatment has been provided in accordance with subsequent provisions of this Ordinance.

Except as hereinafter provided, it shall be unlawful to construct or maintain in areas where sanitary sewer service is available any privy, privy vault, septic tank, cesspool, or other facility intended or used for the disposal of wastewater.

The owner of all houses, buildings, or properties used for human occupancy, employment, recreation, or other purposes, situated within the District and abutting any street, alley, or right-

of-way in which there is now located a public sanitary or combined sewer of the District, is hereby required at his expense to install suitable toilet facilities therein, and to connect to same in accordance with provisions of this Ordinance, within ninety (90) days after date of official notice to do so, provided that said public sewer is within one hundred (100) feet (30.5 meters) of the property line.

At such time as a public sewer becomes available to a property served by a private sewage disposal system, a direct connection shall be made to the public sewer in compliance with this Ordinance. Any septic tanks, cesspools, and similar private sewage disposal facilities shall be properly abandoned. Such abandonment shall be inspected and approved by the appropriate state or local officials.

No statement contained in this article shall be construed to interfere with any additional requirements that may be imposed by the Health Officer of Champaign County or any other regulatory agency.

4.6 District's Responsibility and Liability

The District shall install, own, inspect, operate, and maintain the complete wastewater system, sewers, manholes, pump stations, force mains, and wastewater treatment facilities.

A building sewer permit will only be issued and a sewer connection shall only be allowed if it can be demonstrated that the downstream sewerage facilities, including sewers, pump stations, and wastewater treatment facilities, have sufficient reserve capacity to adequately and efficiently handle the additional anticipated waste load.

4.7 User's Responsibility

All Disposal by any person(s) into the sewer system is unlawful except those discharges in compliance with Federal Standards promulgated pursuant to the Federal Clean Water Act or more stringent State and local standards.

All costs and expenses incidental to the installation, connection and maintenance of the building sewer shall be borne by the user. The user shall indemnify the District from any loss or damage that may directly or indirectly be occasioned by the installation of the building sewer.”

All building sewer shall comply with the Illinois Plumbing code. A separate and independent building sewer shall be provided for every building, and connection to a collection sewer shall occur in a dedicated public street, permanent recorded easement or right-of-way except that where one building stands at the rear of another on an interior lot and no private sewer is available or can be constructed to the rear building through an adjoining alley, court, yard, or driveway, the building sewer from the front building may be extended to the rear building and the whole considered as one building sewer.

No person shall make connection of roof down spouts, exterior foundation drains, area-way drains, or other sources of surface runoff or groundwater to a building sewer or building drain which in turn is connected directly or indirectly to a public sanitary sewer; and,

No person shall discharge or cause to be discharged any storm water, surface water, groundwater, roof runoff, subsurface drainage, uncontaminated cooling water or unpolluted industrial process water to any sanitary sewer; and;

Storm water and all other unpolluted drainage shall be discharged to such sewers as are specifically designated as combined sewers or storm sewers, or to a natural outlet approved by the said District. Industrial cooling water or unpolluted process waters may be discharged, on approval of the said District, to a storm sewer, combined sewer, or natural outlet;

Each user shall, as to each such building or appurtenance so connected to the sanitary sewer, grant permission to the District, to come upon the property and within the premises thereon, of such person(s) to inspect and/or perform sewer tests as may be deemed necessary by the District. Said allowance shall be deemed to include periodic inspections and/or tests as may be determined to be necessary by the District, to maintain, insure, and monitor compliance with the provisions of this Ordinance.

Whenever possible, the building sewer to serve a new building shall be brought to the building at an elevation below the basement floor or crawl space. No below grade plumbing fixtures shall be directly connected by gravity to any portion of the building sewer. Construction of all building drains shall be no lower than the ground floor of any building. Sanitary sewage from all below grade plumbing fixtures shall be lifted by a means that is approved by the District and discharged to the building sewer. No water-operated sewage ejectors shall be used. In all buildings, which any building drain is too low to permit gravity flow to the public sewer, sanitary sewage carried by such building drain shall be lifted by a means which is approved by the District and discharge to the building sewer. No water operated sewage ejector shall be used. The minimum depth of cover shall afford protection from frost. The building sewer shall be laid at a uniform grade and in straight alignment, insofar as possible. Changes in direction shall be made only with properly curved pipe and fittings, unless the break in the line is made at the manhole to facilitate servicing. All building drains shall be equipped with a proper "clean-out" outside the building to facilitate access to the service line for cleaning.

All excavations for building sewer installation shall be adequately guarded with barricades and lights so as to protect the public from hazard. Streets, sidewalks, parkways, and other public property disturbed in the course of the work shall be restored in a manner satisfactory to the District, Village of Mahomet and to the Township Road Commissioner.

All outside installations of sanitary sewer service lines shall be inspected by District personnel prior to backfill. No inspections will be made outside of normal District working hours (8:00 AM to 4:00 PM Monday through Thursday and 8:00 AM through 12 noon on Fridays, prevailing time) or on weekends or District holidays.

Connections with any sewer shall be made only at manholes or other such junctions as may be provided or designated by the permit, and then only in such manner as directed. The connection of a building sewer shall be made in a "Y" or "T" branch, if such branch is available. Connection to said "Y" or "T" shall be by means of an approved rubber connector of suitable size, secured on both ends by means of stainless-steel clamps and in such a manner as to prevent the entrance of ground water into the receiving sewer line both during and after installation.

In the absence of such connection stub, a neat hole may be cut into the sewer to receive a building sewer, which entry in a downstream direction at an angle no greater than 90 degrees to the sewer. A saddle made of rubber and secured to the main line by means of stainless-steel clamps shall be used to make the connection; the spigot end not to extend beyond the inner surface of such sewer. The centerline of a building sewer at the point of connection shall be at the same or a higher level than the centerline of the sewer. Other fittings may be used for the connection only when approved by the General management.

All sanitary sewers constructed to be connected to the District Sewer System as well as building sewer connections shall be constructed of PVC pipe. All pipe and fittings must meet the requirements specified in Article 7.1.

The size and slope of building connecting sewers shall be subject to the approval of the General management. If 6-inch diameter pipe is used, the slope shall not be less than 1/8-inch per foot. If four-inch diameter pipe is used, the slope shall not be less than ¼-inch per foot. Any pipe laid longitudinally in public streets, alleys, or easements which could connect more than one building sewer or could be extended to connect more than one building sewer, and all collecting sewers for which plans and specifications are presented for approval shall not be less than 8-inches in diameter, shall be laid on a minimum grade of four (4) feet per one-thousand (1,000) feet and shall be constructed to a maximum depth to permit further extension thereto. Collecting sewers shall be extended beyond the last house to be served and end at the most distant property line of the last house. House connecting sewers shall be installed or repaired by a licensed plumber, or have the installation or repair directly supervised by a licensed plumber.

Joints on all buildings, sewers, and on any sewers laid longitudinally in public streets, alleys, or permanent easements, up to and including 18-inch diameter, shall be made permanently watertight by one of the following methods:

1. Ductile iron pipe shall be fitted with mechanical joints or push-on joints. Rubber gaskets joint shall conform to AWWA C 111. Bolts and nuts shall be stainless steel.
2. Plastic pipe joints shall conform to specifications in Article 7.1.
3. Joints between different types of pipe shall be made with an approved transition coupling. When reducing from a 6-inch to a 4-inch connection, proper rubber or other approved flexible reducing fittings shall be used.

4. All house connections shall be laid according to Standard Specifications for Water and Sewer Construction in Illinois and as modified in Article 7 of this policy.
5. All boulevards, existing utilities, sidewalks, streets, and seeded areas shall be left in as good a condition as they were prior to the start of any sewer construction and shall be maintained for a period of one (1) year from the date of connection.

4.8 Discharges into Public Sewers:

- A. No person(s) shall make connection of roof, exterior foundation drains, areaway drains, or other sources of surface runoff or groundwater to a building sewer or building drain which in turn is connected directly or indirectly to a public sanitary sewer.
- B. No person shall discharge or cause to be discharged any of the following described waters or wastes to any public sewer:
 1. Any gasoline, benzene, naphtha, fuel oil, or other flammable or explosive liquid, solid, or gas;
 2. Any waters or wastes containing toxic or poisonous solids, liquids, or gases in sufficient quantity, either singly or by interaction with other wastes, to injure or interfere with any sewage treatment process, constitute a hazard to humans or animals, create a public nuisance, or create any hazard in the receiving waters of the sewage treatment plant, including but not limited to cyanides in excess of two (2) mg/l as CN in the wastes as discharged to the public sewer;
 3. Any waters or wastes having a pH lower than 5.5, or having any other corrosive property capable of causing damage or hazard to structures, equipment, and personnel of the sewage works;
 4. Solid or viscous substances in quantities or of such size capable of causing obstruction to the flow in sewers, or other interference with the proper operation of the sewage works such as, but not limited to, ashes, cinders, sand, mud, straw, shavings, metal, glass, rags, feathers, tar, animal or food processing wastes, plastic, wood, un-ground garbage, whole blood, paunch manure, hair and flashings, entrails and paper dishes, cups, milk containers, etc., either whole or ground by garbage grinders.
- C. No person shall discharge or cause to be discharged the following described substances, materials, waters, or wastes if it appears likely in the opinion of the General management that such wastes can harm either the sewers, sewage treatment process or equipment, have an adverse effect on the receiving stream, or can otherwise endanger life, limb, public property, or constitute a nuisance. In forming their opinion as to the acceptability of these

wastes, the General management will give consideration to such factors as the quantities of subject wastes in relation to flows and velocities in the sewers, materials of construction of the sewers, nature of the sewage treatment process, capacity of the sewage treatment plant, degree to treatability of wastes in the sewage treatment plant, and other pertinent factors. The substances prohibited are:

1. Any liquid or vapor having a temperature higher than one hundred fifty (150) degrees F (65) C;
2. Any water or waste containing fats, wax, grease, or oils, whether emulsified or not, in excess of one hundred (100) mg/l or containing substances which may solidify or become viscous at temperatures between thirty-two (32) and one hundred fifty (150) degrees F (0 and 65) C;
3. Any garbage that has not been properly shredded. The installation and operation of any garbage grinder equipped with a motor of one horsepower or greater shall be subject to the review and approval of the General management;
4. Any waters or wastes containing strong acid iron pickling wastes, or concentrated plating solutions whether neutralized or not;
5. Any waters or wastes containing iron, chromium, copper, zinc, and similar objectionable or toxic substances; or wastes exerting an excessive chlorine requirement, to such degree that any such material received in the composite sewage at the sewage treatment works exceeds the limits established by the General management for such materials;
6. Any waters or wastes containing phenols or other taste or odor producing substances, in such concentrations exceeding limits which may be established by the General management as necessary, after treatment of the composite sewage, to meet the requirements of the State, Federal, or other public agencies of jurisdiction for such discharge to the receiving waters;
7. Any radioactive wastes or isotopes of such half-life or concentration as may exceed limits established by the General management in compliance with applicable State or Federal regulations;
8. Any waters or wastes having a pH in excess of (9.5);
9. Materials which exert or cause:

- a. Unusual concentrations of inert suspended solids such as, but not limited to, Fuller's earth, lime slurries, and lime residues and sludge's, or of dissolved solids such as, but not limited to, sodium chloride and sodium sulfate;
 - b. Excessive discoloration such as, but not limited to, dye wastes and vegetable tanning solutions;
 - c. Unusual BOD, chemical oxygen demand, ammonia nitrogen, phosphorus or chlorine requirements in such quantities as to constitute a significant load on the sewage treatment works;
 - d. Unusual volume of flow or concentration of wastes constituting "slugs" as defined herein;
10. Waters or wastes containing substances which are not amenable to treatment or reduction by the wastewater treatment processes employed, or are amenable to treatment only to such degree that the sewage treatment plant effluent cannot meet the requirements of other agencies having jurisdiction over discharge to the receiving waters.
- D. If any waters or wastes are discharged, or are proposed to be discharged to the District sewers, which waters contain the substances or possess the characteristics enumerated in this Article, and which in the judgment of the General management, may have a deleterious effect upon the sewage works, processes, equipment, or receiving waters, or which otherwise create a hazard to life or constitute a public nuisance, the General management may:
- 1. Reject the wastes,
 - 2. Require pre-treatment to an acceptable condition for discharge to the public sewers,
 - 3. Require control over the quantities and rates of discharge, and/or
 - 4. Require payment to cover the added cost of handling and treating the wastes not covered by existing sewer charges under the provision of this Ordinance.
- E. If the General management permits the pre-treatment or equalization of waste flows, the design and installation of the plans and equipment shall be subject to the review of the District Engineer and approval of the Board of Trustees, and subject to the requirements of all applicable codes, ordinances, and laws.
- F. Grease, oil, and sand interceptors shall be provided when, in the opinion of the General management, they are necessary for the proper handling of liquid wastes containing grease

in excessive amounts, or any flammable wastes, and/or other harmful ingredients; except that such interceptors shall not be required for private living quarters or dwelling units.

All interceptors shall be of a type and capacity approved by the General management, and shall be located as to be readily and easily accessible for cleaning and inspection.

- G. Where preliminary treatment or flow-equalizing facilities are provided for any waters or wastes, they shall be maintained continuously in satisfactory and effective operation by the owner at their expense.
- H. When required by the General management, the owner of any property serviced by a building sewer carrying industrial wastes shall install a suitable control manhole together with such necessary meters and other appurtenances in the building sewer to facilitate observation, sampling, and measurement of the wastes. Such manhole, when required, shall be accessible and safely located, and shall be constructed in accordance with plans approved by the General management. The manhole shall be installed by the owner at his expense, and shall be maintained by him so as to be safe and accessible at all times.
- I. All measurements, tests, and analyses of the characteristics of waters and wastes to which reference is made in this Ordinance shall be determined in accordance with the latest edition of "Standard Methods for the Examination of Water and Wastewater", published by the American Public Health Association, and shall be determined at the control manhole provided, or upon suitable samples taken at said control manhole. In the event that no special manhole has been required, the control manhole shall be considered to be the nearest downstream manhole in the public sewer to the point at which the building sewer is connected. Sampling shall be carried out by customarily accepted methods to reflect the effects of constituents upon the sewage works and to determine the existence of hazards to life, limb, and property. (The particular analyses involved will determine whether a twenty-four (24) hour composite of all out falls of a premises is appropriate or whether a grab sample or samples should be taken. Normally, but not always, BOD and suspended solids analyses are obtained from 24-hour composites of all out falls where PH's are determined from periodic grab samples.)
- J. No statement contained in this Article shall be construed as preventing any special agreement or arrangement between the District and any industrial concern whereby an industrial waste of unusual strength or character may be accepted by the District for treatment, subject to payment therefore, by the industrial concern.
- K. The General management and other duly authorized employees of the District bearing proper credentials and identification shall be permitted to enter all properties for the purpose of inspection, observation, measurement sampling, and testing in accordance with the provisions of the Ordinance. The General management or their representatives shall have no authority to inquire into any process including metallurgical, chemical, oil, refining,

ceramic, paper, or other industries beyond that point having a direct bearing on the kind and source of discharge to the sewer or waterways or facilities for waste treatment.

- L. While performing the necessary work on private properties referred to above, the General management or duly authorized employees of the District shall observe all safety rules applicable to the premises established by the company and the company shall be held harmless for injury or death to the District employees and the District shall indemnify the company against loss or damage to its property by District employees and against liability claims and demands for personal injury or property damage asserted against the company and growing out of the gauging and sampling operation, except as such may be caused by negligence or failure of the company to maintain safe conditions.
- M. The General management and other duly authorized employees of the District bearing proper credentials and identification shall be permitted to enter all private properties through which the District holds a duly negotiated permanent easement for the purposes of, but not limited to, inspection, observation, measurement, sampling, repair, and maintenance of any portion of the sewage works lying within said easement. All entry and subsequent work, if any, on said easement, shall be done in full accordance with the terms of the duly negotiated easement, pertaining to the private property involved.

END OF CHAPTER 4

CHAPTER 5 - EXTENSION OF WATER MAINS AND SEWERS

5.1 Requirements for Extension

The Sangamon Valley Public Water District (“SVPWD”) must approve all plans and specifications for any extensions. The developer or party requesting the extension shall be responsible for the cost of any engineering review necessary for the District to approve the plans. To quantify this intent, the District has established the following engineering review fees, made payable via cashier’s check or money order to: “Sangamon Valley Public Water District” at the time of the submittal:

- Preliminary Plat and Plan = \$700
- Final Plat and Plan = \$1,600

Said fees shall be per submittal to the District on any one particular date. If, for reasons beyond the control of the District or the Village of Mahomet, the developer enlarges or modifies the development, or splits the development into additional phases, or changes the number of lots in the development, with the result being changes to the extent, sizes or locations proposed water mains and/or sanitary sewers or other components affecting the District, the developer is required to again pay the aforementioned review fees before the District will consider the revised development plan.

Before any extensions are installed, the plans and specifications must be reviewed and approved by, and a permit obtained from the Illinois Environmental Protection Agency, or other agencies having jurisdiction thereof. Ownership, rights-of-way, and title must be conveyed to SVPWD for all extensions installed and after they are inspected and approved by the District. SVPWD will maintain the mains thereafter.

No extension will be permitted if, in the opinion of the District, the system does not have the necessary capacity to serve the proposed extension. The total cost of all water main extensions, and/or sewer extensions shall be borne by the person(s) requesting the extension, unless it is determined by the SVPWD Board of Trustees, in its sole discretion, that it is to the benefit of SVPWD as a whole to participate in some manner in the construction of the extension.

The review and approval by SVPWD shall pertain only to the matters of water and wastewater extensions that will be dedicated to SVPWD upon approval and acceptance.

5.2 Plan Approval Procedures

- A. **Informal Discussion Phase** - In order to become familiar with these regulations and SVPWD policies and objectives applicable to SVPWD in which the proposed extension lies, the Developer or the party requesting extension is responsible for initiating discussions with SVPWD before preparing complete plans. A discussion with the

Village of Mahomet or any other governmental body other than the District does not serve as a substitute for a discussion with the District.

The purpose of the informal discussion phase, prior to application, is to guide and assist the Developer or person requesting the extension, insofar as possible, in his or her future decisions with a view to avoiding later difficulties and delays. This is the basic policy stage, during which the Developer or person requesting the extension, informally meets with SVPWD. In the course of this meeting, the Developer should make known its tentative plans for subdividing extension and/or development, may exhibit sketch plans and shall be appraised by specific SVPWD policies and objectives that the District may have for the area in question. Discussion at this phase shall involve the entire area of ownership and anticipated development to be serviced by SVPWD.

- B. Mandatory Request for water and sewer service for tracts within the Village of Mahomet corporate limits.** Prior to the District considering any agreement with a Developer to provide potable water and sanitary sewer service to any tract within or proposed to be within the corporate limits of the Village of Mahomet, the Village of Mahomet shall make such a request for said water and sewer services to the District Trustees - in the form of a water and sewer service agreement. This agreement shall be mutually negotiated between the Village and the District and must be approved through a majority vote of both the Water District Trustees and the Village of Mahomet trustees prior to any Water District informal discussion with the Developer. The District Trustees will have the sole decision on rather to grant such a request. At no time may the District Trustees grant potable water and sewer service if the District's potable water and wastewater treatment, collection, and/or distribution systems capacity do not meet current or future customer needs, or if the connection of the Development in question could, in the District's opinion, cause environmental harm and/or if compliance and/or capacity issues exist with the Illinois EPA.
- C. Preliminary Plan Phase** - The purpose of the preliminary plan phase, insofar as possible, is to assist the Developer or person requesting the extension and SVPWD in determining whether the proposed extension conforms to the standards and requirements of this Ordinance. Any preliminary plans required by the Village of Mahomet (as they pertain to water and sanitary sewer issues) must be submitted to and approved by SVPWD's Engineer and accepted by the SVPWD Board of Trustees prior to the Developer attempting to seek Village of Mahomet approval.

The Board of Trustees shall pursue one of the following courses of action:

1. Deny approval of the preliminary plans.
2. Approve the preliminary plans.
3. Approve the preliminary plans, subject to minor corrections or additions.
4. Continue the meeting to another date.

- D. **Final Construction Plans** - Final plans and Final Plat for water main and sewer extensions shall be submitted to SVPWD Board of Trustees for approval. The plans shall be prepared by or under the direct supervision of a registered Professional Engineer of Illinois. The Final Plat shall be prepared by or under the direct supervision of a registered Illinois Professional Land Surveyor. The plans shall be signed by the Chairman of the SVPWD Board of Trustees stating approval of the plans and specifications. In the case of new subdivisions, this approval can be either before or after submission and approval by the authority having jurisdiction over the land use or subdivision of the land. Three (3) sets of approved plans and specifications shall be delivered to SVPWD prior to starting any construction operations.

Neither the Final Plans nor the Final Plat will be approved by the District when the approved engineering plans require a connection to any part of the District's public water system and/or the District's public sanitary sewer system, unless the land is already within the District's Boundary Limits, or the owner of the Development has submitted to the District a legally-sufficient petition to annex into the District, or the District and owner have already executed an Annexation Agreement.

- E. **Construction Performance Bond** - The Developer or person requesting the extension must furnish, as a condition of approval of the final plans a Construction Performance Bond in an amount equal to One Hundred Twenty-Five Percent (125%) of the estimated costs of the improvements as prepared by the Developer's engineer and as approved by SVPWD's Engineer which are to be dedicated to SVPWD. The Construction Performance Bond shall be in the form of a cash deposit, Cashier's Check, Performance Bond, Irrevocable Letter of Credit (in the form and format prescribed by the District) or other surety acceptable to the Board. To be considered valid and approvable, said bond shall be approved by the District's Attorney and District Engineer.

Should the Developer fail to perform the Developer's obligation to construct and correct defects in water and sanitary sewer improvements as required by these regulations or fail to pay contractors, the District may liquidate any performance security in the District's possession and use the proceeds to construct or correct the improvements in whole or in part as the District, in its sole discretion, deems appropriate.

5.3 Construction Standards

All construction shall be in accordance with the current Standard Specifications for Water and Sewer Main Construction in Illinois and the Illinois Environmental Protection Agency standards listed below. Where the aforementioned standards are in conflict with this ordinance, this ordinance shall prevail.

1. For sanitary sewers and related components: 35 Ill. Adm. Code 370.
2. For water distribution components. 35 Ill. Adm. Code 653 and the Recommended Standards for Water Works, latest edition, as issued by The Great Lakes-Upper Mississippi River Board of State and Provincial Public Health and Environmental Manages.

5.4 Deviations from Standards

In the event it is deemed desirable to deviate from these standards, the developer, or user must submit, in writing, a request to the Board of Trustees stating the degree of deviation and the reasons why such deviation is necessary or desirable. The deviation must be approved in writing. The decision whether to grant any such waiver is solely at the discretion of the Board of Trustees of the District.

5.5 Construction Observation

All materials and each part or detail of the work is subject to approval and engineering observation at all times by the Engineer representing the Developer, with oversight by SVPWD. The Developer or person requesting the extension shall provide 100%, full-time engineering observation inspection during all construction operations (which includes systems testing). Failure to provide full time engineering observation during construction operations may lead to the District stopping the work. The District will hold the Developer's engineer professionally responsible for the quantity, quality and accuracy of the information provided to the District in the Record Drawings. If the District finds that erroneous or inaccurate Record Drawing information has been provided to the District, the Developer's engineer shall correct said information and re-submit the Record Drawing information, at no cost to the District.

The Engineer representing the Developer or person requesting the extension shall certify that the work was constructed in compliance with the plans and specifications as approved by SVPWD.

5.6 Acceptance of District Extensions

When construction of SVPWD extensions is completed, the Engineer for the Developer shall make a written request to SVPWD to accept the work and release the Construction Performance Bond.

Within twenty (20) consecutive calendar days of said written request, SVPWD's Engineer and General management will make an inspection of the work. Within ten (10) consecutive calendar days of said visit, SVPWD's will compile and issue to the Developer and the District a list of any improvements that do not meet the plans and specifications as approved by the SVPWD Board of Trustees.

All work shall first meet the approval of the SVPWD District Engineer before the Board of Trustees will release all or part of the Construction Performance Bond. All work includes complete

installation of all underground utilities, including buried cable lines, telephone lines and electrical power lines.

The SVPWD Board of Trustees shall issue the authority for use of the water or wastewater extension.

5.7 Record Drawings

After completion of the project and prior to acceptance by the SVPWD, the Developer's Engineer shall furnish the SVPWD Engineer with three (3) complete paper sets of signed "Record Drawings" plans with each sheet clearly marked "Record Drawings" in the lower right-hand corner. Said three paper copies shall be provided in the 22" x 34" sheet size. In addition, two (2) sets of half-size (11" x 17") copies of the above "Record Drawings" plans of the water distribution and sewerage collections sheets shall be furnished, along with one (1) electronic copy in Adobe Acrobat (.pdf) file type, plus one electronic copy in AutoCAD or Microstation format with all object enabler files included. All Record Drawing plans shall indicate the final location of all improvements. Included shall be measurements sufficient in detail to locate points of future service connections. The location of all curb boxes and sewer service connections shall be indicated on the "Record Drawing" plans, by measurement from permanent, readily-observable surface features.

5.8 Maintenance Bond

The Developer or person requesting the extension must furnish, as a condition of acceptance of the SVPWD improvements, a Maintenance Bond, cash deposit, or other surety acceptable to the Board in an amount equal to Thirty Percent (30%) of the District Engineer-approved estimated construction cost of the water system extensions and improvements.

The condition of the Maintenance Bond shall be that the principal shall guarantee maintenance of the SVPWD improvements for a period of one (2) year from the release of the Construction Performance Bond.

The SVPWD Board of Trustees will release the Maintenance Bond upon written recommended approval by the SVPWD District Engineer and satisfaction of the conditions set by the SVPWD Board of Trustees.

END OF CHAPTER 5

*This page is intentionally left blank -
for two sided printing.*

CHAPTER 6 - CONSTRUCTION REQUIREMENTS FOR WATER DISTRIBUTION SYSTEM

6.1 Design Criteria

All design criteria shall conform with the current "Standard Specifications for Water and Sewer Construction in Illinois", except for the following items:

- A. Water main sizes shall depend upon factors such as the demand requirements, the pressure requirements in the distribution system, and plans for the expansion of the District. All mains located within the distribution system shall be a minimum of six (6) inches in diameter.
- B. The layout of the water mains shall be as to serve adequately all lots and tracts with connection to the District. The mains shall be looped and valved to permit shutting off service to only a small number of connections for repairs or maintenance. Preferably, disruption of service should be limited to one block. Looped mains shall be provided in all locations. The design and construction shall include the placement of tees, crosses, etc. where future development indicates looping will be required. Unless, if in the District Engineer's opinion, there is a reasonable compelling reason to not do so, all water mains shall be placed within the street right-of-way between the sidewalk and back-of-curb and not within permanent easements proposed in the lots' front yards along said street right-of-way.
- C. If the District Engineer recommends allowing the construction of water mains which are not looped or dead ends, they shall be equipped with a fire hydrant as specified in Section 6.2, Paragraph C.
- D. Fire hydrants shall be installed throughout the entire distribution system. The hydrant spacing shall provide for hose lines not exceeding 350 feet to a house. Hydrants along the street shall be at a maximum 500-foot interval. During the Final Plans preparation stage, as described in Section 5.2 and prior to Final Plan submission to the District, the Developer shall submit the proposed fire hydrant layout to the local Fire Protection District for that agency's written approval. Developer shall submit said written Fire Protection District approval with the Final Plat submission to the District.
- E. All fire hydrants and post-type flushing hydrants shall be equipped with an auxiliary gate valve (with retainer-gland restrained mechanical joint ends) located between the main and the hydrant to allow for the removal and/or replacement of said hydrant without disruption of adjacent water service.

- F. All fire hydrant leads shall be a minimum six (6) inch diameter, AWWA C-900 DR-18 PVC pipe. All fire hydrants shall be provided with a 6-inch auxiliary gate valve on the lead between the hydrant and the main, for isolation of the hydrant. Fire hydrant auxiliary valves shall comply with Section J of this Chapter. All fire hydrants' exterior exposed surfaces shall be painted red.
- G. All fire hydrants shall have a 5¼-inch main valve, two 2½-inch diameter hose connections, and one 4½-inch pumper connection. The 4½-inch pumper connection shall face the street and shall be uniform in site configuration. Threads shall match those presently in use for the local Fire Department. All fire hydrants shall be installed plumb and shall be set so that the lowest hose connection is not less than fourteen (14) inches and not more than twenty-six (26) inches above the surrounding finished grade, as required by State of Illinois Public Act 85-343. Fire Hydrants shall be placed so that no existing above-ground fixed object is within 48 inches of the hydrant, as measure horizontally. When placing the hydrant, a minimum of ¼ cubic yard of coarse uniformly-graded, round stone shall be placed at and around the base of the hydrant at the weep hole, to ensure proper drainage of the hydrant after use. The hydrant shall be restrained via a Class 53 ductile iron anchor pipe coupling, installed to counteract the pressure of water exerted thereon, without the need for concrete blocking or strapping on the hydrant lead. Care shall be taken to ensure that the hydrant weep hole is not covered or obstructed by concrete. The hydrant shall be set on a concrete block to ensure a firm bearing for the hydrant base. All fire hydrants shall be installed as per AWWA Manual M17 – "Fire Hydrants: Installation, Field Testing, and Maintenance", latest edition and as per Detail "E" in the Appendix of this ordinance.
- H. All plugs, caps, tees, bends, and fittings deflecting 22-1/2 degrees or more on mains shall be provided with approved mechanical joint restraint system sufficient to allow normal operation without displacement. The restraint system used must include adequate line restraints on the water main to prevent displacement of the water main line after construction or during repairs. Because thrust restraint is provided by joint restraint, concrete thrust blocking is not required.

Mechanical joint restraint shall be incorporated in the design of the follower gland and shall include a restraining mechanism which when actuated, imparts a wedging action against the pipe, increasing the resistance as the pressure increases. Flexibility of the joint shall be maintained after burial. All mechanical joint restraint devices shall have a working pressure of at least 250 psi with a minimum safety factor of 2-to-1. All mechanical joint restraint devices shall be approved prior to installation and shall be inspected prior to burial.

- I. All water mains shall be buried with a tracer wire capable of indicating the exact horizontal location of said water main using conventional locating equipment designed for use with this type of installation. The installation of tracer wire shall provide for easy access by location personnel but not inhibit the use of any valve or other termination

point. The tracer wire shall be taped to the top of the water main and not wrapped around the main. Tracer wire shall meet the following requirements:

1. Tracer wire shall be direct-bury rated #12 AWG solid copper or copper-clad steel wire with 30 mil HDPE jacketing, blue in color. Stranded copper wire, THHN electrical wire, and bare copper wire are prohibited.
 2. Tracer wire shall be brought up inside each valve box and terminated within four (4) inches of the lid, in a manner directed by the District.
 3. Buried tracer wire connections shall be via moisture displacement connectors, Copperhead Industries' SnakeBite connectors, 3M DBR connectors, or equal. Buried connections made by twisting wires together and taping them will not be accepted.
 4. To achieve District acceptance of the tracer wire installation, the Developer shall successfully test each run of installed tracer wire, in the District staff's presence. If the installed tracer wire does not function to enable location of the main, it shall be replaced at the Developer's cost, re-tested and re-worked until it functions as intended.
 5. Provide a Tracer Wire Access Box adjacent to each fire hydrant barrel and for every 1,200 L.F. of water main. Each tracer wire access box shall be made of cast iron with a permanently attached 3" x 12" ABS tube to enable it to be secured to the ground. Each lid shall be blue in color for water service. Each lid shall be tamper resistant and lockable, and shall be opened by a standard AWWW pentagon shaped key. Each unit shall have stainless steel connectors on the bottom side to which the tracer wires shall be attached. Selection of the tracer wire access box type shall be as follows:
 - a. Where the Access Box is to be located in a paved area (including asphalt, oil & chip, crushed stone, or concrete pavements), said box shall be Copperhead Industries' SnakePit Roadway model RB14*2T-SW or equal with two terminal, switchable blue lid.
 - b. Where the Access Box is located in a grassed unpaved area, said box shall be Copperhead Industries' SnakePit Lite Duty XL Adjustable model LDXL36*2T-ADJ-SW or equal with two terminal, switchable blue lid.
 - c. Where a water service line crosses the property line within a driveway, provide a two-terminal tracer wire access point with blue-color switchable lid, that being a cast iron "SnakePit Paved Driveway Access Point" device, Copperhead Industries' model CD14*2T-SW.
- J. Valves shall be uniformly located in some standard area such as the street or curb line to facilitate their location. A valve box, with its cover at the finished grade, shall always be placed over a buried valve. All valve boxes shall be equipped with an approved centering device capable of preventing the box from being dislocated during burial.

Valves shall be located on all branches from feeder mains and between distributors and fire hydrants. Three valves shall be provided at crosses and two valves shall be provided at tees; the valves shall be placed on the smaller lines at each cross or tee. On arterial mains and minor distributors, valves should be placed at least every six hundred (600) feet.

- K. All service connections shall be supplied with corporation stops to each lot. The service pipe shall conform to the District Ordinances. (See Section 3.12). Water service lines shall be installed to the approximate property line and shall terminate at the property line with a curb stop valve, with service box, stem and cover. No service connection shall pass through property other than the property it serves. Individual services are required for each customer.
- L. Minimum cover for water mains and water services shall be 48 vertical inches. In addition, where water mains pass under public streets' pavements and paved driveways, water mains shall be protected from frost penetration by providing 1-inch thick rigid board extruded polystyrene insulation above and beside the main in an inverted U-shape configuration, as directed by the District Engineer.
- M. All permits required must be obtained by the Developer, (i.e., Illinois Environmental Protection Agency Permit, Illinois Department of Natural Resources erosion control permit as applicable, and Illinois Department of Transportation Permits).
- N. Written approval will be required from the appropriate authority where work will take place within an existing township, county or State of Illinois road right-of-way.
- O. All connections of new mains into the District's existing water system shall be accomplished via "live taps" using tapping sleeves and valves. The tapping effort shall be executed so that the District is not required to call in a boil order for the existing system, as the result of the connection. Tapping valves shall conform to the requirements of AWWA C-500 and shall be resilient seat models having flanged by mechanical joint ends. Tapping valve inlet flange shall meet ANSI B16.1 Class 125. Tapping valves shall be Clow Model F-5093, Mueller Model H687 or equivalent. Tapping sleeves shall be fabricated of either stainless steel, ductile iron or cast iron bodies. Cast iron tapping sleeves shall have mechanical joint ends. Tapping sleeves shall be Clow Model F-5205, Mueller Model H615, Ford Style FAST, U.S. Pipe model T-28 or equivalent.
- P. Dead-end mains or mains that are to be extended in the future shall terminate with a factory-manufactured "post type" flushing hydrant. Temporary blow-off pipes will not be accepted. Flushing hydrants shall be John C. Kupferle Company Eclipse Model #2 Post Hydrant or equal. Flushing hydrants shall be painted red. Each shall be furnished with a 2-inch mechanical joint inlet, 2-inch PVC inlet pipe, an auxiliary gate valve with valve box

(all meeting Section 6.2-G) for hydrant isolation, ductile iron exterior casing, and heavy wall cast iron top stock. Flushing hydrants shall be fitted with one 2½-inch diameter flushing nozzle, shall open left, and shall be installed as per AWWA Manual M17 – “Fire Hydrants: Installation, Field Testing, and Maintenance”, latest edition and as per Detail “H” provided in the Appendix to this ordinance.

6.2 Materials

- A. All water main pipe shall be polyvinyl chloride (PVC) conforming to the requirements of AWWA C900 for pipes up to 12-inch diameter and AWWA C905 for 14-inch pipe and larger, DR-18, with a minimum sustained 235 psi internal working pressure for C900 pipe and 200 psi internal pressure for C905 pipe. PVC pipe shall be manufactured from virgin PVC compounds meeting the requirements of cell classification 12454 as defined in ASTM D1784. The PVC compounds shall be certified by NSF International to ANSI/NSF Standard 61. The gaskets shall conform to the requirements of ASTM F477. Joints shall be integral with the pipe and shall comply with ASTM D3139. Pipe shall have standard cast iron outer diameters. Water main pipe shall be blue in color. Pipe shall be manufactured to ductile iron pipe sizes for use as a pressure conduit without transition style gaskets. Pipe having iron pipe size (IPS) diameters requiring transition gaskets to connect ductile iron pipe (DIP) size fittings and valves will not be accepted.

An exception to the use of the aforementioned material will be where water mains are constructed under a stream or river crossings. In the case of stream or river crossings the use of ductile iron, river crossing, and directional drilling of water main pipe may be required where there is a danger of translocation of the water main by movement of water, ice or debris in the water course or by movement of the overlaying material due to erosion or other factors. With that, stream or river crossings shall be made utilizing spline-restrained joint PVC pipe, CertainTeed Certa-Lok C900/RJ pipe, Class 235 DR-18 grade or equal, installed via horizontal directional drilling methods. Said pipe shall be light blue in color. All such installations will require a burial depth of 3.5 feet below the stream bed or as required by the federal or state permitting agency for the crossing. Decisions regarding the use of substitute material or construction methods will be at the discretion of the General management.

Ductile iron pipe shall conform to AWWA C-150, tar coated with rubber gasket, push-on joints. All fittings used on ductile iron pipe shall be installed as per Section 6.1 H, above. The use of ductile iron pipe and the location of such use shall be approved by the General management prior to installation.

- B. All fittings shall be compact ductile iron fitting that conform to AWWA C153. Fittings shall have restrained mechanical joint ends, restrained with EBAA Iron Series 2000PV or equal retainer glands. All joints for ductile iron pipe shall conform to AWWA C111. All joints for pipe shall be push-on joints. In addition, the 20 lineal feet of water main pipe on either

side of a fitting shall be furnished with joint restraint, EBAA Iron Series 1900 or equal split serrated restraining harness, for thrust restraint beyond the fitting. Pipe line joint restraint beyond fittings and changes in direction shall comply with Detail "I" in the Appendix to this ordinance.

C. Fire hydrants shall be dry-barrel type designed for 150 pounds per square inch working pressure conforming to AWWA C502 with valve opening at least 5 inches in diameter. Outlets shall have American National fire-hose coupling threads. All working parts shall be bronze. Fire hydrant connecting shoe shall be mechanical joint restrained with retainer glands. Hydrants shall be latest stock pattern produced by manufacturer. Hydrants shall open counterclockwise. Hydrants shall be as follows:

1. Kennedy (Guardian)
2. Clow (Model F2500)
3. Mueller (Modern Centurion)

D. All service pipes shall be not less than 1.25" diameter SDR-9 Copper Tube Size Polyethylene water pipe conforming to ASTM D2737. All water services shall be sized by the Developer's engineer, in accordance with the Illinois State Plumbing Code, latest edition. Developer's engineer shall submit with the final construction plans the water service sizing calculations to the District Engineer for review approval. Sizing of water services without a basis of design based on projected plumbing fixture counts per tract of land will not be accepted. The District will not be responsible for sizing the portions of the service lines. Copper service lines are not permitted. Lines larger than two inches shall be PVC, ASTM B2241, NSF 61 conforming to water main specifications as described in Section 6.2 of this document. All water services shall be provided with tracer wire, for the user's benefit in locating the service. Said tracer wire shall conform to Article 6.1-I of this Section. In addition, where the water service line crosses the property line within a driveway, the developer shall provide a two-terminal tracer wire access point with blue-color switchable lid, that being a cast iron "SnakePit Paved Driveway Access Point" device, Copperhead Industries' model CD14*2T-SW.

1. Water service lines into the house must be equal to or less than the minimum 1.25-inch diameter, except as noted in paragraph D above. No oversized water service lines are permitted unless the house builder demonstrates the need by plumbing sizing calculations as per the Illinois State Plumbing Code and is willing to go back to the water main and properly install an oversized connection to the main.
2. All water meters for new service connections must be purchased from the District at the price previously established by the District. Developers and house builders are advised to contact the District prior to plumbing "rough in" work because District-issued meters are furnished in "kit form" which includes the couplings and meters connections needed to complete the work. The District requires information such as whether the water service line is entering through a floor or wall - in advance, in order

to properly furnish the appropriate components. Meter valves shall be furnished by the plumber and must be a minimum 600 WOG ball type valve and not of the "sweat" type.

3. If the residence being served was constructed with a crawl space, the master meter connection must be on the ground floor. The meter installation may be positioned in a furnace room or closet as long as it is, in the General management's opinion, easily accessible. District-issued meters are issued to the house builder/contractor with "contractor" heads attached. At the time a house is sold, the District will remove said "contractor" head and install a generator unit, which requires a wire or conduit through the house siding to the outside, for installation of a remote reading device. The house builder may be required to remove and re-install siding and trim when required by the District, if the District staff is unable to properly install the remote reading device.
 4. The District requires the installation of a second water meter for outside faucets. Developers and house builders are duly advised to all for the installation of these meters during the plumbing "rough in", since changes for said second meter is very costly if added after the house is finished. Meters for separate inside and outside water usage must be located in the same location.
 5. The District prohibits the grounding of any building's electrical systems to the water system or water service lines, since most of the District's water system is constructed of non-conductive plastic piping, rendering it of little value as a ground. Instead, electrical contractors shall install outside ground rods for electrical system grounding.
- E. All corporation stops, tapping saddles, connections to the service pipe, and curb stops shall be fabricated of brass and shall be provided with outlets suitable for copper tube size polyethylene pipe, compression type connections as manufactured by Ford Meter Company or an equal approved by the District and must use a stainless-steel insert in the HDPE pipe. (See Detail "A" in Appendix A.) Curb stops shall be of the "roundway" type. All fittings used on water service lines shall be brass, suitable for use with copper tube size polyethylene pipe and be of the compression type. No "barbed" fittings nor fittings which require the use of hose clamps will be permitted.
- F. Service boxes shall be of the best quality iron, with the base of ample size to completely house the service stop, and of such construction that it shall be capable of extension from a minimum of three feet, six inches (3'-6") in length, number EA2-45-40-36R, as manufactured by the Ford Meter Box Inc. or equivalent. Boxes shall be 1.25-inch in diameter for stops one and one-quarter (1-1/4) inches and smaller. Boxes for stops over one and one-quarter inches (1-1/4") will require "enlarged" base adaptors. Boxes shall be furnished with a cast iron lid with a brass pentagon head plug. All service boxes up to two (2) inch curb stop size shall be arched bottom with internal rod.

- G. Valves shall be iron body, brass-mounted, non-rising stem, and resilient seat for working pressure of not less than 200 pounds per square inch and shall conform to AWWA C509.

Valves shall have properly restrained mechanical joint ends fitted with stainless steel bolts and nuts. All valves shall have a clear water-way equal to the full nominal diameter, shall have a 4 mil epoxy coating on the exterior surfaces, and shall be opened by turning counter-clockwise ("open left").

Valve boxes shall be screw type, cast-iron, extension type with flared base and cast-iron cover. Slip type valve boxes are not permitted. Valve boxes shall be constructed of ASTM A48 cast iron, heavy-duty type with Class 35B rating. Minimum thickness of metal on valve boxes shall be 3/16-inch. Minimum inside diameter of valve box shaft shall be 5¼ inches. Boxes shall be installed over outside gate valves and be of length that can be adapted, without full extension, to depth of cover required for the top of the box to be flush with grade. The word "WATER" shall be cast in the cover. Valve box covers shall be of the non-locking type, fabricated of cast iron meeting ASTM A48, Class 35B, heavy-duty grade, manufactured by Tyler Union, Star Pipe Products, or equal. Box and cover shall be furnished with a 1.5 mil asphaltic bituminous coating. All valve boxes shall be equipped with an approved centering device (Valve Box Adaptor II as manufactured by Adaptor, Inc. or equal) capable of preventing the box from being dislocated during burial. All valve boxes shall be installed in accordance with AWWA Manual M44, Distribution Valves, latest edition.

6.3 Construction Standards

- A. Trench backfill is required whenever the trench is within two feet of a paved surface. Paved surfaces are defined to include sidewalks, streets, alleys, curbs, gutters, and bike paths constructed of Portland cement concrete, asphalt or stone aggregate. All construction pressure tests and leakage tests shall conform to the current "Standard Specifications for Water and Sewer Construction in Illinois", latest edition. The District Engineer and the General management shall be notified at least twenty-four (24) hours prior to testing of the water system. The Certifying Engineer, for the developer shall be present at the time of testing.
- B. For sanitary sewer main construction, trench backfill (where noted herein) is defined as IDOT-approved Coarse Aggregate, gradation CA-6 or CA-10, mechanically compacted to a minimum of 95% of optimum density when tested as in accordance with ASTM D1557, Modified Proctor. For water main construction, trench backfill shall be defined as fine sand, IDOT approved FA-10. Controlled Low Strength Material (CLSM), meeting IDOT Standard Specifications for Road and Bridge Construction, latest edition, is an acceptable substitute material for trench backfill under pavements and sidewalks. Pit run gravel (defined as material excavated directly from an existing

bank in a pit and delivered to the jobsite without further processing, such as crushing, screening, washing or classifying) is not approved for trench backfill. Frozen material of any kind is not acceptable for trench backfill. Compaction of trench backfill by means of water jetting is prohibited.

- C. The Developer's construction contractor shall (in the presence of the District staff, at its discretion) take the sterilization samples after the system has passed the pressure and leakage tests, in order to demonstrate that the proposed extension of the water distribution system is bacteriologically safe. If it chooses to, the District may take custody of the samples and deliver to the Developer's testing laboratory. Developer shall pay all laboratory testing costs for confirming that the water mains are bacteriologically safe. Developer shall fill out and complete the IEPA Operating Permit forms and submit to the District for approval, in order to secure the IEPA Operating Permit. Water main flushing and disinfection shall be executed in accordance with AWWA C651 – "AWWA Standard for Disinfecting Water Mains", latest edition. The District will not place the constructed water main into service until the fully executed IEPA Operating Permit is received by the District.
- D. All water main installation work shall conform to AWWA C605, latest edition, except as modified herein. The pipe embedment details provided herein supersede the pipe embedment requirements of AWWA C605. Developer is responsible for filling and flushing water main extensions as required by AWWA C605, including the need to provide temporary vents in the main for expelling air and for providing the 3 foot/second minimum flushing velocity needed to cleanse the main of debris and other foreign materials.
- E. Developer is responsible for hydrostatic pressure testing and leak testing of the main, prior to disinfection. Hydrostatic pressure testing and leakage testing shall be executed in the presence of the District Engineer or General management, in accordance with AWWA C605. All mains shall be tested at a pressure of not less than 100 psi.

6.4 Horizontal Direction Drilling Requirements

A. Horizontal Directional Drilling Permitting and Safety

- 1. Prior to performing work involving horizontal direction drilling (HDD) under a local or state right-of-way permit, the Permittee or Contractor shall secure a written permit from the government body with the authority having jurisdiction of said public right-of-way. Permittee or Contractor shall pay all permit fees and secure any related bonds associated with the permit. A .pdf copy of the executed permit shall be provided by email or in person to the District not less than seven (7) days prior to initiating work.

2. Permittee or Contractor Shall implement the following safety guidelines:

- a. Perform all boring operations in compliance with OSHA guidelines and ensure that all personnel are properly trained and equipped to work in the public right-of-way.
- b. Traffic control shall be maintained as directed in the permit.

B. Horizontal Directional Drilling Construction Guidelines

All construction work shall be performed in accordance with Sangamon Valley Public Water District following guidelines:

1. For all work involving horizontal directional drilling under a Right-of-way Permit, the Permittee or its Contractor shall perform the tasks outlined as follows: section.

- a. Tickets from and issued by the Joint Utility Locating Information for Excavators (J.U.L.I.E.) one-call system must reference the public-right-away permit number and the Governmental Agency name authorizing such permit.
- b. Permittee or its Contractor shall positively locate/expose (by exploratory excavations, i.e., potholing) all existing parallel potable water mains, potable water service lines, and sanitary sewer mains and sanitary sewer service lines at the beginning and ending of all bores, every 200 feet if it is within 5 feet of the proposed alignment, or every 50 feet if it is within 3 feet of the proposed alignment, and additionally it shall be required that the Permittee (or Contractor) positively locate/expose (by exploratory excavations, i.e., potholing) all water and sanitary services crossed within the boring path.

c. Definitions:

- i. Water Service Connection - means a pipe, with appurtenances, used to conduct water from the main to the premises to be served. The connection, pipe and all appurtenances required as part of this installation shall be owned, installed and maintained by the user.
- ii. Water Main - Main - The word "main", whenever the same appears herein, means the supply pipe, located in the public highway and/or easement, and owned and maintained by the District, to which water service connections are attached to supply water service to a premises.
- iii. Waste Water Service Connection – means a pipe, with appurtenances, used to collect and remove wastewater from the premises being served to the sewer main. The connection, pipe and all appurtenances required as part of this installation shall be installed and maintained by the user.

- iv. Sewer Main "Public Sewer" shall mean a sewer collection pipe in which all owners of abutting properties have equal rights, and is controlled by the District.

END OF CHAPTER 6

*This page is intentionally left blank -
for two sided printing.*

CHAPTER 7 - CONSTRUCTION REQUIREMENTS FOR SANITARY SEWER SYSTEM

7.1 Design Criteria

- A. The adequacy of the existing sanitary sewers to which the proposed development is to outlet into must first be determined by the developer. If the existing sewers are not adequate, it shall be the developer's responsibility to find an outlet for the sanitary sewers. This work shall be done in cooperation with the District Engineer and the General management.
- B. All design calculations must be submitted to the District Engineer for approval.
- C. All permits required must be obtained by the developer, (i.e., Illinois Environmental Protection Agency Permit, applicable federal permits, and/or Illinois Department of Transportation Permits, Township and County Highway).
- D. Written approval will be required where work will take place within an existing township road right-of-way.
- E. All sanitary sewer work shall be done in accordance with the current "Standard Specifications for Water and Sewer Construction in Illinois" and the Environmental Protection Agency of the State of Illinois; except as follows:
 - 1. Sanitary sewer mains shall be a minimum of eight (8) inches in diameter.
 - 2. Maximum distance between manholes shall be 400 feet.
 - 3. Manholes shall be constructed in accordance with Detail "D" in the Appendix. All new manholes shall be fitted with internal chimney seals, as manufactured by Cretex Specialty Products Classic External Seal or equal. Drop connections shall be provided when the influent the sewer is more than 24" above the effluent sewer. Drop connections shall be provided as per Detail "G" of the Appendix of this ordinance. Connections into existing manholes shall be accomplished by core-drilling with sealing made by a Concrete Manhole Adaptor unit by Fernco or equal and grout. Saw-cut connections into manholes is prohibited. Each pipe penetration into the manhole shall be sealed via rubber manhole boot, PSX Direct Drive by Press-Seal Corporation or Kore-N-Seal 106/406 Series pipe-to-connector by Trelleborg.

4. All main sewer lines shall be terminated with a manhole. Cleanouts are prohibited.
5. Each lot shall be provided with a wye or tee connection located near the center of the lot (with pancake plug). Developer may utilize ADS Corporation's Inserta-Tee unit as a substitute for the tee. Said unit shall be SDR-26 wall pipe with stainless steel hardware. All service lines and wyes shall be constructed to a watertight, approved method. The service shall extend to a point two feet inside of the property line of the lot being served. Ninety-degree (90°) bends are prohibited on any portion of the sanitary sewer service, including that portion on private property.

The invert of all service connections made at manholes must be at the top of the main line pipe as shown in Detail "D";

6. Any service stub which is seven (7) feet or greater from the finished surface shall be provided with a riser to bring the service within seven (7) feet of the surface, all such service wyes shall be encased with 6 inches of concrete, (with pancake plug);
7. Drop connections for service at manholes will not be allowed;
8. Back lot line sanitary sewers shall be provided with manholes at all street crossings;
9. Except in paved areas, the top of all manhole rims shall be set two (2) inches above the finished ground line;
10. Slope: All sewers shall be designed and constructed to give mean velocities, of not less than 2.0 feet per second, when flowing full, based on Manning's formula using an "n" value of 0.013. Sewers on slopes greater than 20% shall be protected as per 35 Ill. Adm. Code 370. 320. The following minimum slopes shall be provided; however, slopes greater than these are desirable:

Minimum Slope in Feet		
<i>Sewer Size</i>	<i>Slope per 100 feet</i>	<i>Flow capacity (MGD)</i>
8-inch	0.40	0.49
10-inch	0.28	0.75
12-inch	0.22	1.07

11. Services shall be not less than 6" diameter with a minimum 1/8" per foot slope.

12. Minimum cover shall be 3.5 feet from finished grade to top of pipe for gravity sanitary sewer mains or sewage force mains. Minimum cover for sanitary sewer service lines is specified in Section 7.3-A herein. Special structural protection shall be provided for cases where there is less than the minimum cover.

13. The type of sanitary sewer pipe for sewer mains shall be:

Polyvinyl Chloride (PVC) ASTM D3034, SDR-26; bell and spigot for elastomeric gasket joints with a minimum cell class of 12454 B or C (sizes to 15"). Joints shall conform to ASTM D3212, and gaskets to ASTM F477, for flexible elastomeric gasket joints. All sanitary sewer pipe shall be green.

All river or lake crossings shall be constructed of butt fusion welded high density polyethylene (HDPE) pipe with cast iron outer diameter and Class DR-11 or better or spline-restrained PVC force main pipe (North American Pipe Corp. Certa-Lok pipe cast iron outer diameter Class DR-18 C900 pipe or equal) enclosed in a steel casing pipe.

Large diameter sewer pipe specifications and or installation modifications that may be required due to excessive depths of installation shall conform to that specified in Standard Specifications for Water and Sewer Construction in Illinois and shall be approved prior to installation by the District Engineer.

14. All force main pipe and appurtenances shall be constructed to water main standards as specified herein, except that said pipe need not be NSF 61 certified. All sanitary force mains shall be provided with tracer wire conforming to Section 6.1-I of this ordinance. Tracer wire shall be routed into air release vaults. All force mains shall be pressure tested to 1.5 times the shut-off head of the pumps discharging into the force main.

The high points of all force mains shall be provided with automatic air release valves provided inside valve vaults, 4-ft. diameter minimum. Air release valves shall be the combination air release and vacuum type, A.R.I. model D-023 NS or equal, with stainless steel body, sized by Developer's engineer for the conditions encountered, using the valve manufacturer's sizing software. Developer's engineer shall submit with the Final Plans the sizing calculations utilized. The valve shall be equipped with a non-slam discharge-throttling attachment, allows for free air intake, but throttles the air discharge.

15. The type of service pipe material from the wye connection or service stub, whichever comes first, shall be:

a. Plastic pipe:

1. 4" services - Polyvinyl Chloride Pipe, Schedule 40 with solvent welded joints conforming to ASTM D1784, ASTM D1785 or ASTM D2564.
 2. 6" services - Polyvinyl Chloride Pipe, ASTM D3034, SDR-26, bell and spigot for elastomeric gasket joints, as specified above for main line sewer installations.
- b. Fittings shall be of the same material as the pipe.
 - c. Adaptors shall be provided as required to join PVC pipe to pipe, fittings and equipment of other materials.
- F. Sanitary sewers shall be installed in dedicated public rights-of-way – except as noted herein. Unless, if in the District Engineer’s opinion, there is a compelling reason to not do so, all sanitary sewer mains shall be placed within the street right-of-way between the sidewalk and back-of-curb and not within permanent easements proposed in the lots’ front yards along said street right-of-way. Sanitary sewers shall not be placed in lot side yards, except in unusual or special circumstances and when approved by the District Engineer. If the sanitary sewer is to be placed in permanent easement, such easements and rights-of- way shall be of sufficient width and the sewers to be installed at such locations as to permit open cut installation, maintenance and repair within the confines of the permanent easement or right-of-way without relocation or other unreasonable interference with other public utilities located therein and so as to meet the following minimum standards:
1. Twenty (20) foot width plus 5 feet for each additional utility.
 2. Two (2) additional feet for each 12 inches in diameter or portions thereof, for sewers in excess of 24 inches in diameter.
 3. Sewers exceeding fifteen (15) feet in depth, additional width may be required.

7.2 Sewage Pumping Stations

- A. All sewage pumping stations shall be submersible type and shall be approved by the District Engineer during the planning stage. All sewage pumping stations shall be supplied with standby power generators fueled by natural gas or propane and equipped with automatic transfer switches. Larger pump stations’ generators shall be diesel-fired, when so directed by the District Engineer, for cost or other reasons. Sewage pumping stations shall each be equipped with a SCADA system capable of adapting to the system currently in use by the District.

- A. All design calculations, including generator sizing calculations, shall be submitted to the District Engineer for approval.
- B. All sewage pumping stations shall meet 35 Ill. Adm. Code 370, except as noted herein. The developer's engineer shall provide buoyancy calculations, pump calculations, pump selections, and other Basis of Design criteria with the Final Plan submittal, all demonstrating compliance with this provision. Additional pump station requirements:
1. The pump station design shall meet NFPA 820 – “Standard for Fire Protection in Wastewater Treatment and Collection Facilities”, latest edition. Developer's engineer shall provide documentation demonstrating compliance with this standard, and variances proposed, if any.
 2. All check valves shall be horizontally positioned. Vertical check valves will not be permitted. Check valves shall be air-cushioned swing check valves, with outside lever, weight, and air cushion chamber. The valve shall be provided external adjustable counterweight to initiate valve closure, external air cushion chamber to dampen valve closure, with the closing speed being adjustable. The valve shall have a cast or ductile iron body, disc, and cover, stainless steel hinge shafts, flanged ends meeting 125-lb ANSI standards, and stainless steel body seat, resilient field replaceable seat ring on disc. Approved check valves are the following or equal:
 - a. G.A. Industries, Inc.
 - b. Valve & Primer Corporation, APCO.
 - c. Henry Pratt, 8501 Series
 3. Isolation valves inside the station valve vault shall be eccentric plug valves. Said valves shall be non-lubricated, resilient seated eccentric plug valve in compliance with AWWA C517. The valves shall provide a drip-tight shut-off up to full pressure rating of valve with pressure in either direction. The valves shall provide grease zerk fittings in upper bonnet and lower body bearing for sludge applications. Each valve shall be a 100% full port valve, having a port area of 100% of the connecting pipe's open area. Each valve shall have a 175-psig pressure rating for valves, cast iron body, ASTM A126, Grade B. Bonnet shall be ASTM A126 Grade B cast iron or nickel aluminum bronze alloy C95500. The valve shall have nickel seats, Buna-N material for V-packing, U-cup, or O-ring seals. The valve plug shall be coated with Hycar. The valve shall have flanged ends, 125-pound ANSI standards, stainless steel bearings. For valves 4-inch and smaller the valve shall be actuated with a lever actuator. For all others, provide a gear actuator. Approved plug valve manufacturers are:

- a. DeZurik.
 - b. Henry Pratt
 - c. Val-Matic
4. Indicating, totalizing and recording flow measurement facilities shall be provided at pumping stations with a 400 gpm (0.58 MGD) or greater design peak flow.
 5. Variable frequency drivers shall be furnished on all sewage pump stations, 400 gpm or greater design peak flow. Variable frequency driver, types, models and manufacturers shall be selected by the District Engineer.
 6. All metal components (including ladders, float brackets, bolts, nuts, and hardware but excluding pipe and access hatches), within the station's wetwell shall be Type 316 stainless steel.
 7. Wetwell and vault access hatches shall be channel type units, fabricated of aluminum with all Type 316 stainless steel hardware. Where, in the opinion of the District Engineer, access hatches are near roadways or access drives, said hatches shall be designed for an H-20 load rating. All others shall be design for a 300 pound per square foot (PSF) load rating.
 8. Control panels shall have NEMA 4X stainless steel enclosures with a dead-front design for security purposes.
 9. Control panels shall include SCADA-based telemetry to telemeter flow data, and pump station status and alarm conditions to the District via the internet. Said system shall be consistent and compatible with the District's SCADA system current at the time of design of the system.

7.3 Construction Standards

- A. All construction shall be in accordance with the current "Standard Specifications for Water and Sewer Construction in Illinois" and the Environmental Protection Agency of the State of Illinois, except as, and in addition to, the following:
 1. The entire area around the pipe shall be bedded with compacted coarse aggregate material, CA-6 gradation. For dry trench bottoms, said trench backfill shall be IDOT approved FA-1 or FA-10. Pit run gravel (defined as material excavated directly from an existing bank in a pit and delivered to the jobsite without further processing, such as crushing, screening, washing or classifying) is not approved for trench

backfill. For wet or moist trench bottoms, said trench backfill shall be IDOT approved CA-7. No soil shall be used for bedding material. The entire pipe shall be covered with this special backfill. Bedding under the pipe shall be not less than 4-inches thick.

2. The haunching and initial backfilling shall be placed completely under the haunches and up each side in uniform layers not exceeding 6 inches in depth, with each layer carefully and uniformly tamped. Haunching and initial backfilling material shall be IDOT approved CA-6. The trench backfill effort shall comply with Standard Drawing No. 2 in the "Standard Specifications for Water and Sewer Construction in Illinois, latest edition". The slopes of the trench sidewalls as depicted in this standard drawing shall be modified as needed to meet OSHA rules. The Developer and his/her contractors and not the District, is responsible for complying with OSHA rules that apply to the construction of the improvements.
3. The minimum cover for sewer mains and service lines shall be three (3) feet. All lines shall be capable of transmitting direct light between manholes.
4. Infiltration shall not exceed two hundred (200) gallons per day per inch diameter per mile. This test procedure is to be used only for sewers located below the water table, otherwise exfiltration or air tests shall be conducted. The District Engineer and the General management shall be notified at least twenty-four (24) hours prior to testing of the sanitary sewer system. The Certifying Engineer for the developer shall be present at the time of testing. If the sewer(s) subjected to the air testing, infiltration testing and/or exfiltration testing specified herein do not meet the limits specified herein and/or those in the Standard Specifications for Water and Sewer Construction in Illinois, latest edition, the Developer shall utilize internal televising to locate the possible source of defect(s) that have caused
5. Exact location of all service wye connections shall be shown on the "Record Drawings", as measured from the nearest downstream manhole.
6. Unstable trench bottom material shall be removed and replaced with suitable, course material such as CA-7 as specified in Standard Specifications for Water and Sewer Construction in Illinois, Article 20-2.20A.
7. Selected granular backfill as specified herein shall be used whenever the trench is within two feet of the edge of a paved surface.
8. Deflection testing shall be performed on all sanitary sewer mains as per Section 31 of the Standard Specifications for Water and Sewer Construction in Illinois, latest edition, except that the initial testing shall be done using a 95% mandrel regardless of the time elapsed after backfilling. All sections failing to pass the test shall be

repaired and re-tested. If, at least 30 days have passed since backfill and base course have been placed and compacted, including backfilling of repaired sections, a 92.5% testing device may be used. If the deflection testing as specified herein is not successful due to excessive pipe deflection and failure to correct said deficiency, said failed sanitary sewer(s) shall be dug up and replaced at the Developer's cost.

7.4 Television Inspection

After the completion of any new sewer main or development including new sewer mains, and prior to acceptance by the District, an internal television (TV) inspection of those sewer mains is required at the expense of the Developer. The Developer shall first clean the sanitary sewers to be televised of all debris, mud and dirt before initiating the TV inspection effort. All water remaining in the sewer from the cleaning operations shall be flushed out. The vendor doing the inspection shall be approved by the District prior to completion of the construction. Said vendor shall have not less than five (5) years proven experience in internal televised inspection work and said vendor shall provide documentation of this experience, before initiating the TV inspection effort. Televising shall be performed via high definition closed circuit television (HDCCTV) equipment including a high definition (640 x 480 pixel) camera with optical zoom, pan-and-tilt camera head. The software being used for the CCTV work shall be NASSCO-Pipeline Assessment Certification Program (PACP) certified. Camera speed during the TV'ing work shall be slow enough to inspect each pipe joint, tee connection, any defects, any illegal connections, infiltration and inflow sources, and deposits and said speed shall not exceed 30 feet/minute. In addition to televising the sewer, all manholes shall be panned with the video camera and visually inspected. The Developer will also be responsible for the cost of any additional TV inspection cost beyond this initial inspection.

The internal TV inspection effort shall be documented by means of high definition digital videotaping. Analog videotaping will not be accepted. The televising vendor shall also record in a written log all defects, service lines, pipe footages, discovered conditions as well as accurate footages of all service taps from the starting manhole. Within twenty-one days after completion of the internal TV inspection effort, Developer shall furnish to the District Engineer with the video record of the TV inspection work and TV logs. The video record of the TV inspection work shall be furnish in digital video disk (DVD) or memory stick, along with three (3) paper copies of the Video Log Sheets plus one Adobe Acrobat file (pdf format).

END OF CHAPTER 7

CHAPTER 8 - PENALTY FOR VIOLATION

8.1 Designated

Whoever shall violate any of the provisions of this Ordinance shall be guilty of a misdemeanor and shall be fined not less than Fifty (\$50.00) Dollars and not more than Five Hundred (\$500.00) Dollars for each offense. Each day the violation continues shall be deemed a separate offense.

In addition, any violation shall be subject to injunction enjoining further violations and mandatorily enjoining compliance by removal of existing violations.

The District may seek injunctive relief together or separately from any penal sanction.

8.2 Illegal Connections to District Sanitary Sewer System

No person shall make connection of roof down spouts, exterior foundation drains, areaway drains, field tiles, or other sources of surface runoff or groundwater to a building sewer or building drain which in turn is connected directly or indirectly to a District sanitary sewer.

No person shall discharge or cause to be discharged any storm water, surface water, groundwater, roof runoff, subsurface drainage, uncontaminated cooling water or unpolluted industrial process water to any District sanitary sewer.

Storm water and all other unpolluted drainage shall be discharged to such sewers as are specifically designated as storm sewers, or to a natural outlet approved by the said District. Industrial cooling water or unpolluted process waters may be discharged, on approval of the said District, to a storm sewer, or natural outlet.

END OF CHAPTER 8

*This page is intentionally left blank -
for two sided printing.*

CHAPTER 9 - SEVERABILITY-PUBLICATION-EFFECTIVE DATE

9.1 Severability

If any provision(s) of this Ordinance shall be held to be unconstitutional, or invalid for other reasons, such unconstitutionality or invalidity shall not affect the validity of the remaining provisions of this Ordinance.

9.2 Publication

This Ordinance shall be published in accordance with the provisions of 70 ILCS/0.01, Section 3705 Public Water District Act (formerly Chapter 111 2/3 in Public Utilities Illinois Revised Statutes, Section 188) et seq.

9.3 Effective Date

This Ordinance shall be effective after its passage and approval as provided by law. The effective date of this Ordinance is April 25th, 2023.

PASSED AND APPROVED this 24th day of April, 2023
SANGAMON VALLEY PUBLIC WATER DISTRICT

Meghan Hennesy
Chairman, Board of Trustees

ATTEST:

Sonya Brock
District Secretary

All designations and headings of chapters, articles, divisions, and sections are intended only for convenience in arrangement and as mere "catch words" to indicate the contents of such chapters, articles, divisions or section, whether printed in boldface type or italics. They shall not be deemed or taken to be any part or title of such chapters, articles, divisions or sections; nor unless expressly so provided, shall they be so deemed upon amendment or re-enactment, or shall they be construed to govern, limit, modify, alter or in any other manner affect the scope, meaning or intent of any of the provisions of this Ordinance.

END OF CHAPTER 9

*This page is intentionally left blank -
for two sided printing.*

APPENDIX

Detail "A" – Water Service Connection Detail

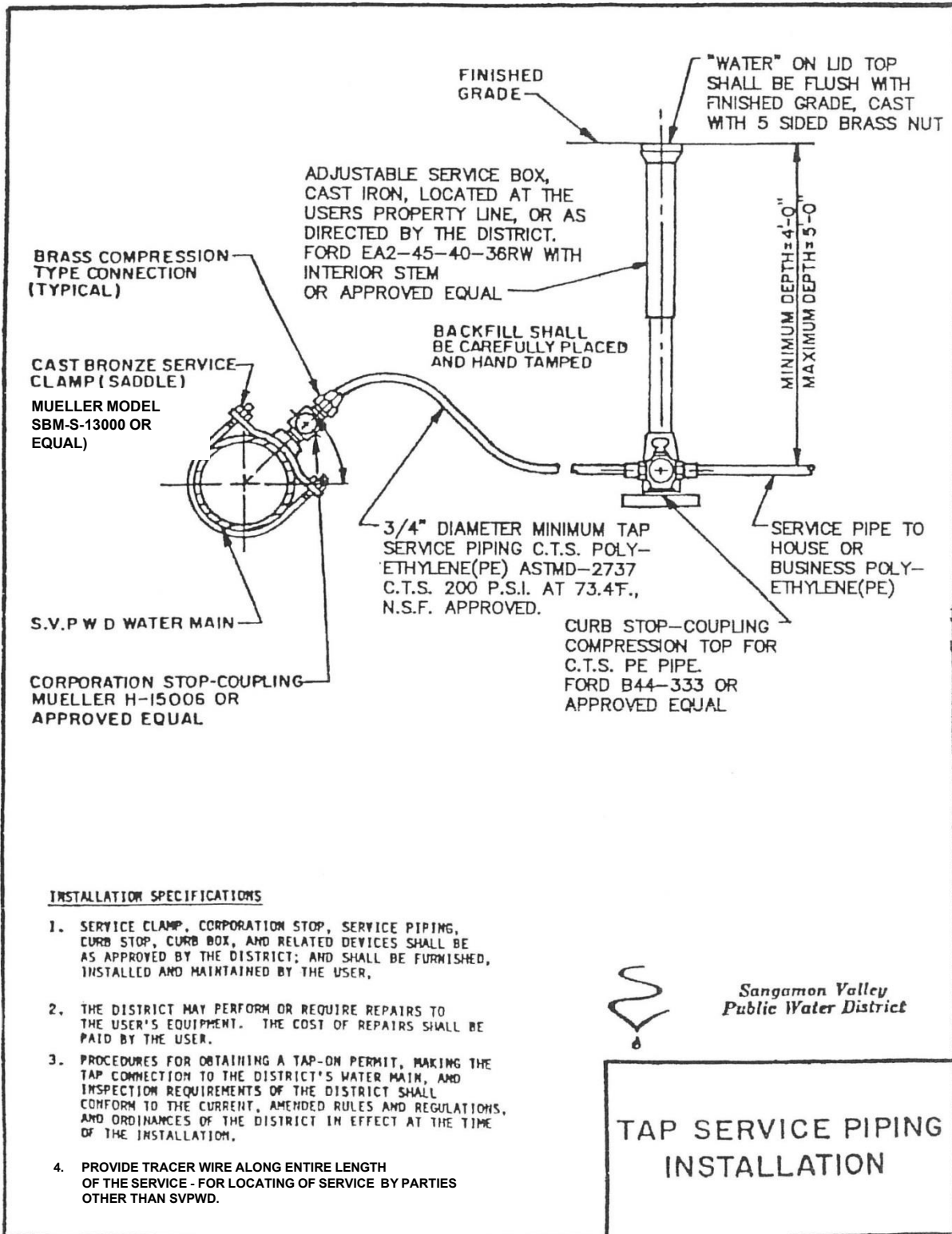

REV. 8/7/95 STANDARD - 1989

APPENDIX

Detail "B" – Sanitary Service Connection Detail

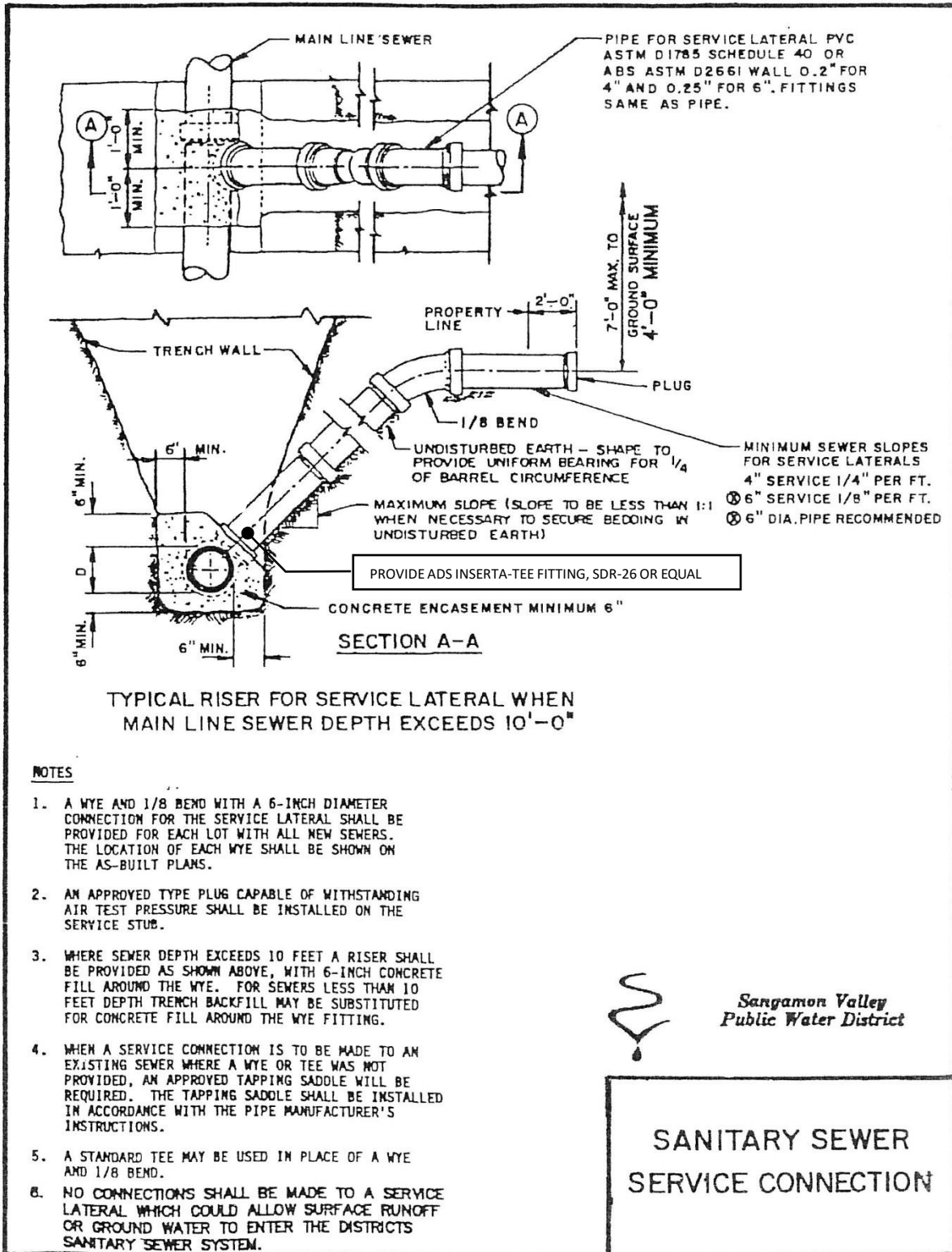

REV. 8/7/95

STANDARD-1989

APPENDIX

Detail "C" – Water Meter Installation Detail

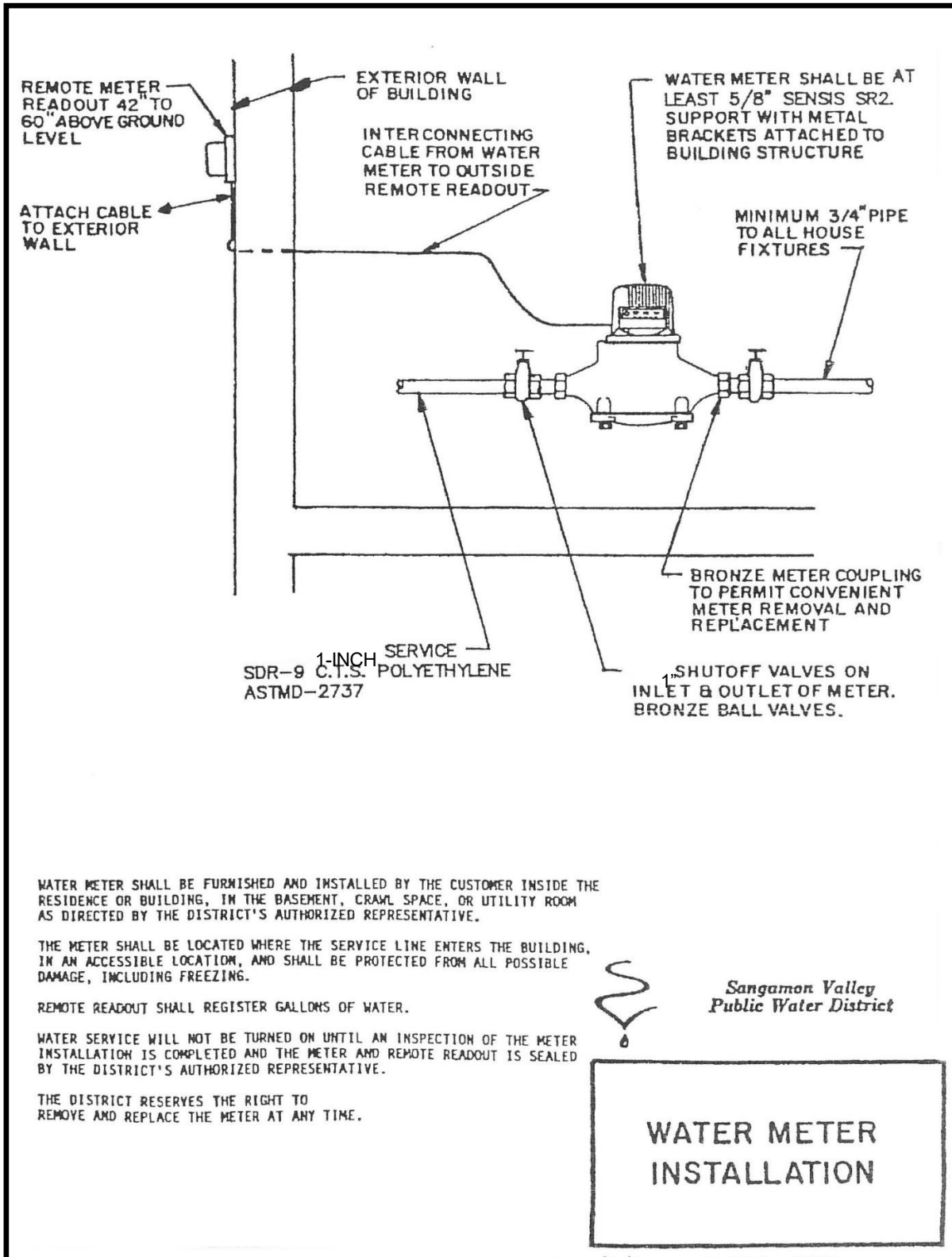

WATER METER SHALL BE FURNISHED AND INSTALLED BY THE CUSTOMER INSIDE THE RESIDENCE OR BUILDING, IN THE BASEMENT, CRAWL SPACE, OR UTILITY ROOM AS DIRECTED BY THE DISTRICT'S AUTHORIZED REPRESENTATIVE.

THE METER SHALL BE LOCATED WHERE THE SERVICE LINE ENTERS THE BUILDING, IN AN ACCESSIBLE LOCATION, AND SHALL BE PROTECTED FROM ALL POSSIBLE DAMAGE, INCLUDING FREEZING.

REMOTE READOUT SHALL REGISTER GALLONS OF WATER.

WATER SERVICE WILL NOT BE TURNED ON UNTIL AN INSPECTION OF THE METER INSTALLATION IS COMPLETED AND THE METER AND REMOTE READOUT IS SEALED BY THE DISTRICT'S AUTHORIZED REPRESENTATIVE.

THE DISTRICT RESERVES THE RIGHT TO REMOVE AND REPLACE THE METER AT ANY TIME.



Sangamon Valley
Public Water District

**WATER METER
INSTALLATION**

REV. 8/7/95 STANDARD 1989

APPENDIX

Detail "D" – Typical Manhole Detail

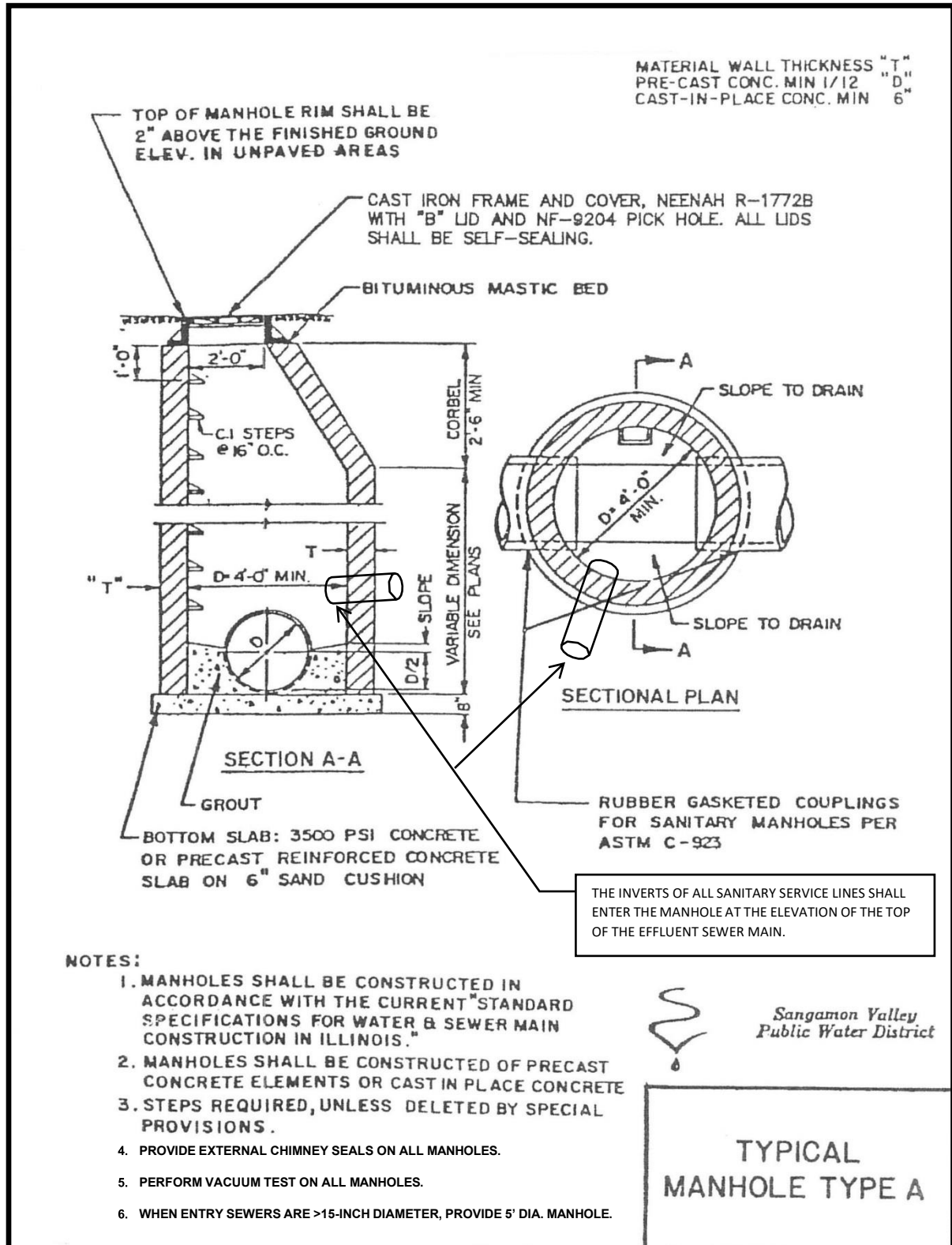

REV. 07-24-2019

APPENDIX

Detail "E" – Typical Fire Hydrant Detail

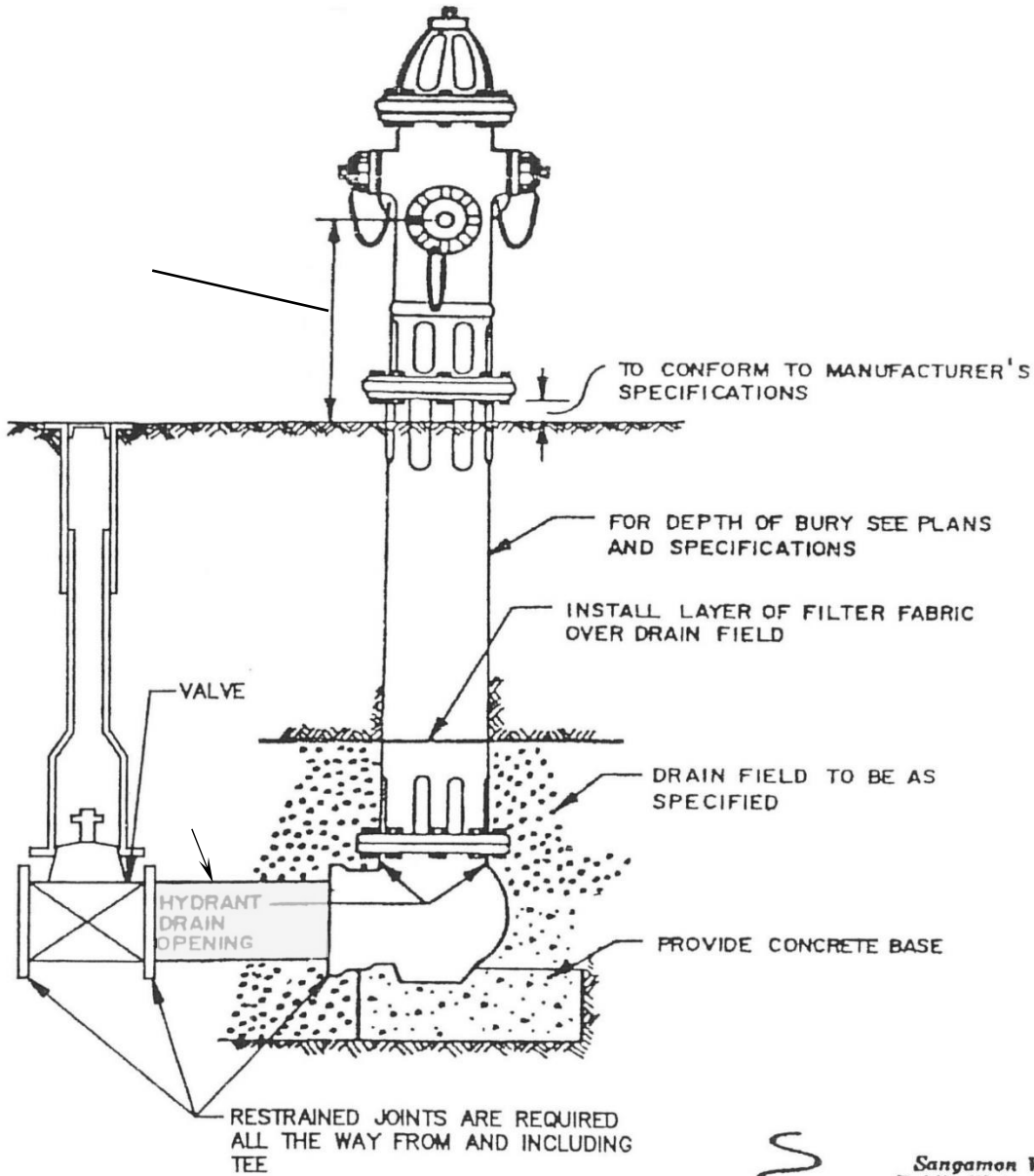

 Sangamon Valley
Public Water District

TYPICAL
HYDRANT
INSTALLATION

REV. 8/7/95 STANDARD -1989

APPENDIX

Detail "F" – Typical Water Valve Box Detail

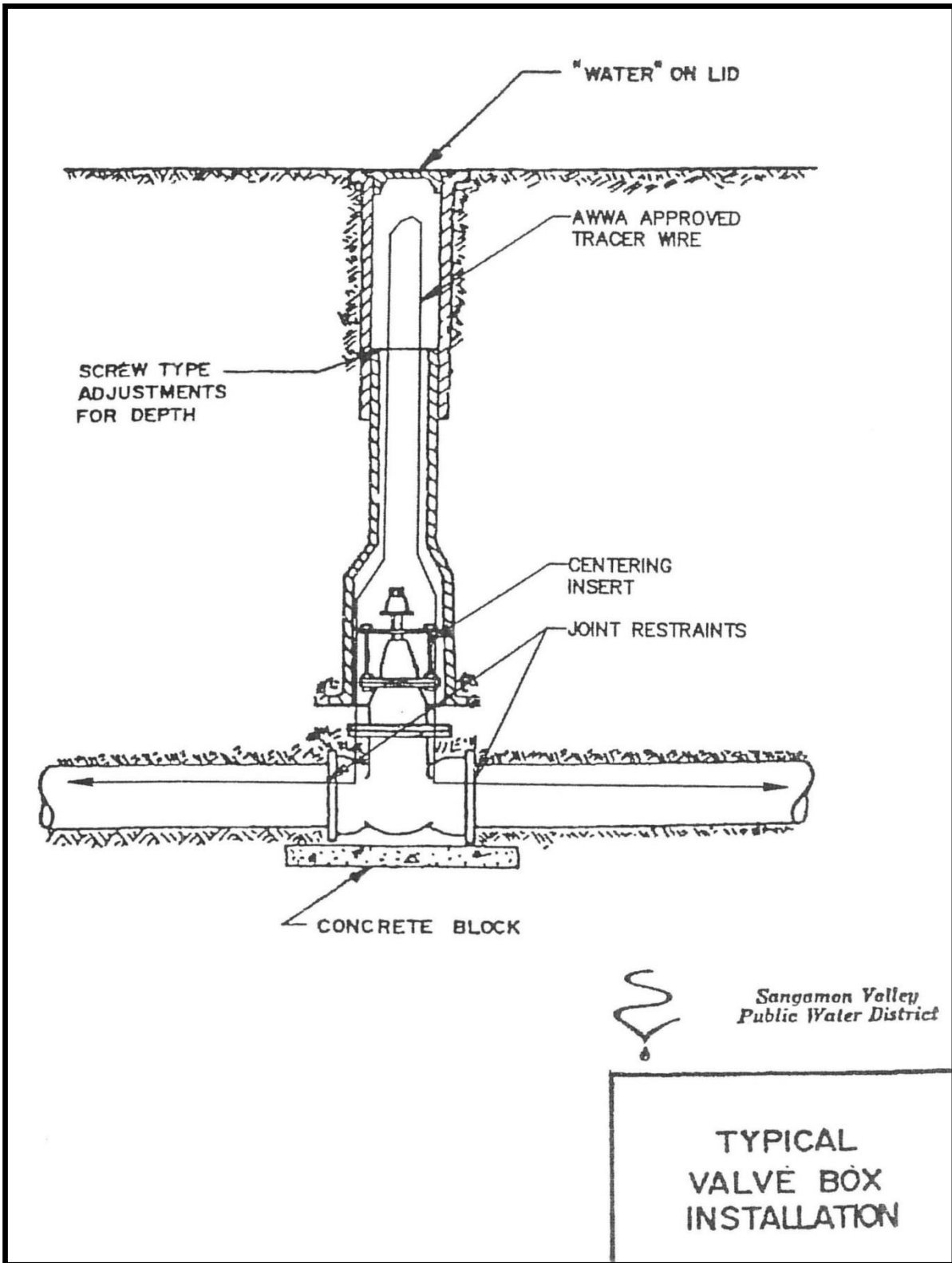

REV. 8/7/95 STANDARD - 1989

APPENDIX

Detail "G" – Typical Inside Drop Connection Detail

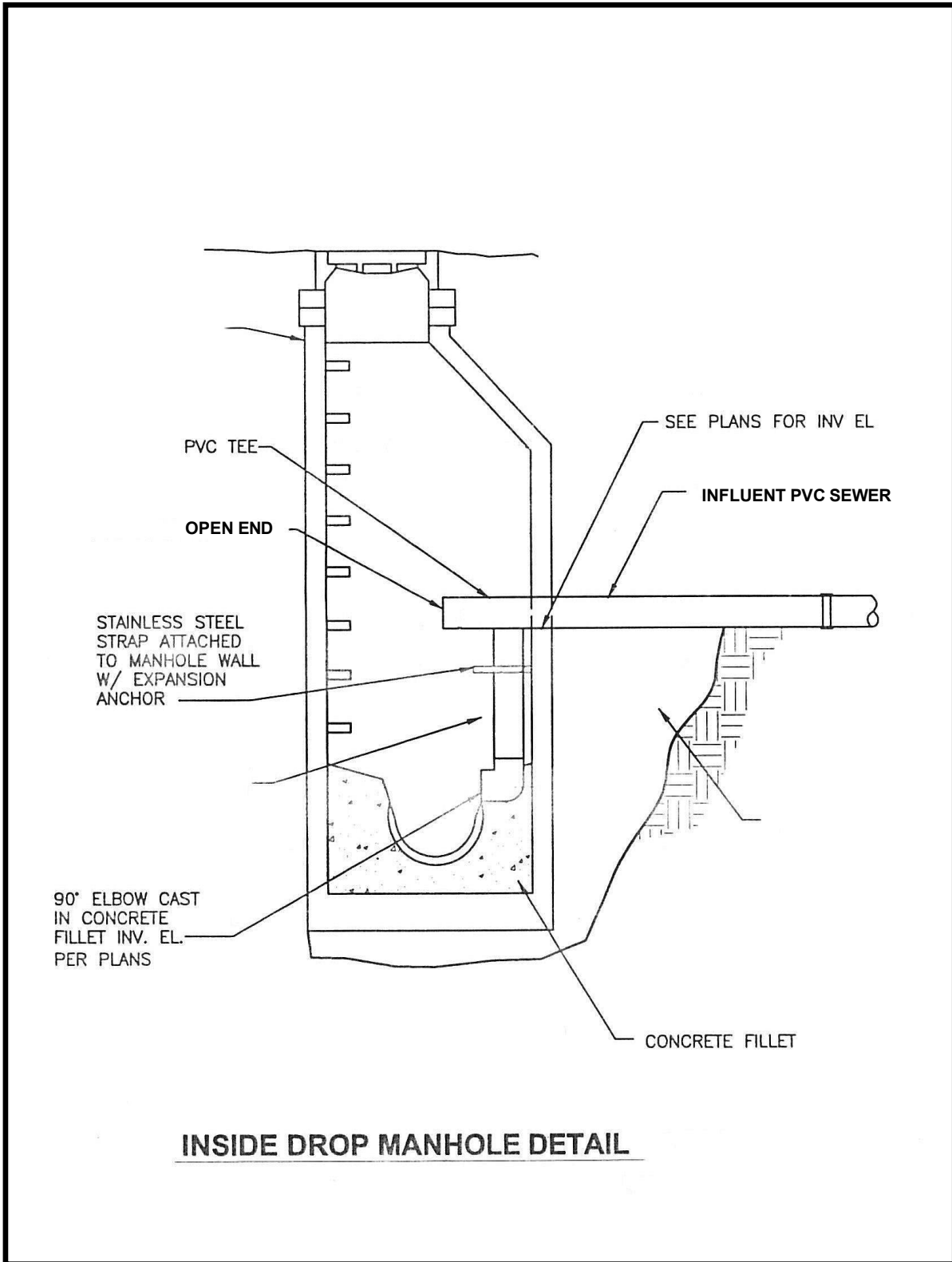

APPENDIX

Detail "H" – Typical Post Hydrant Detail

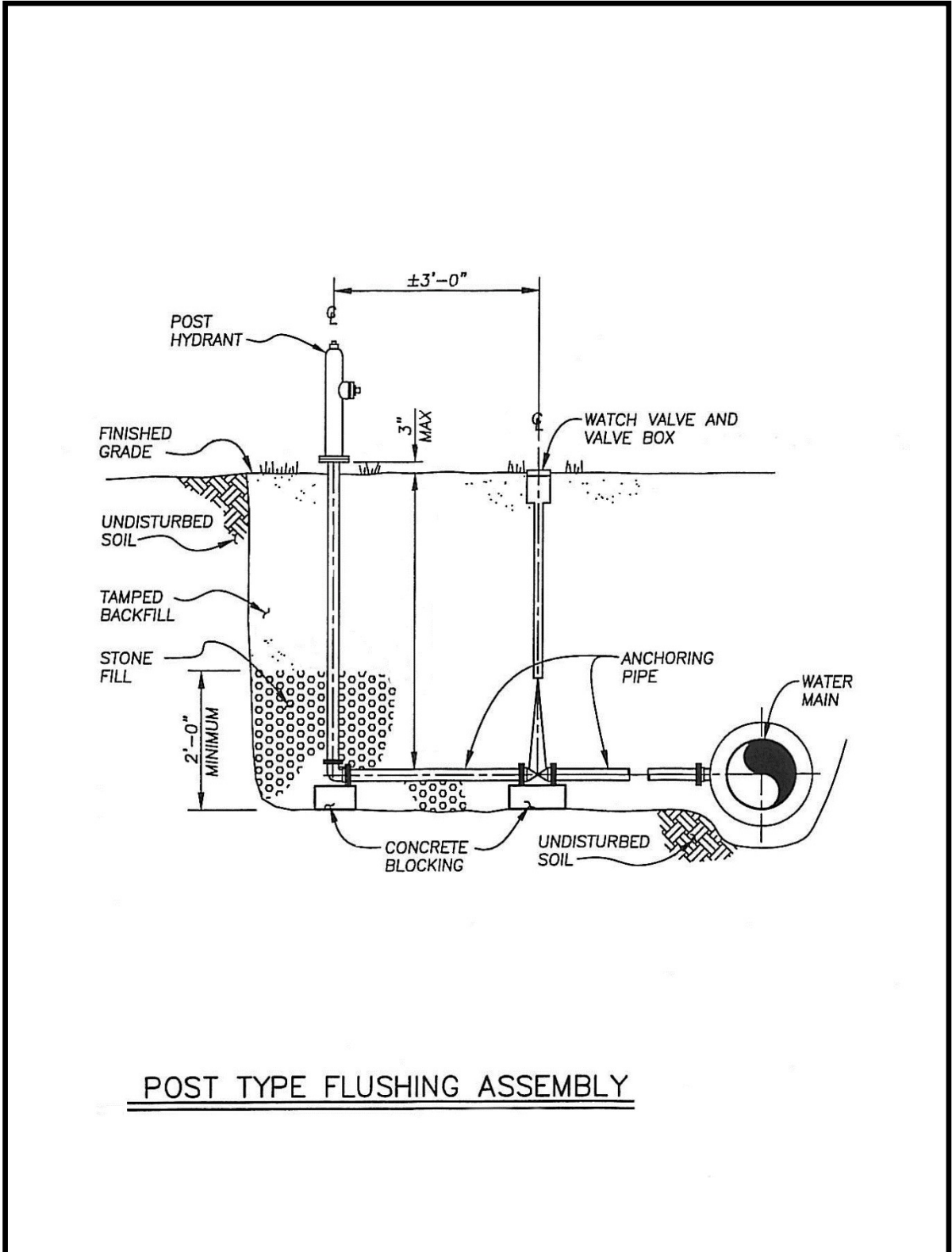

APPENDIX

Detail "I" – Water Main Joint Restraint Detail

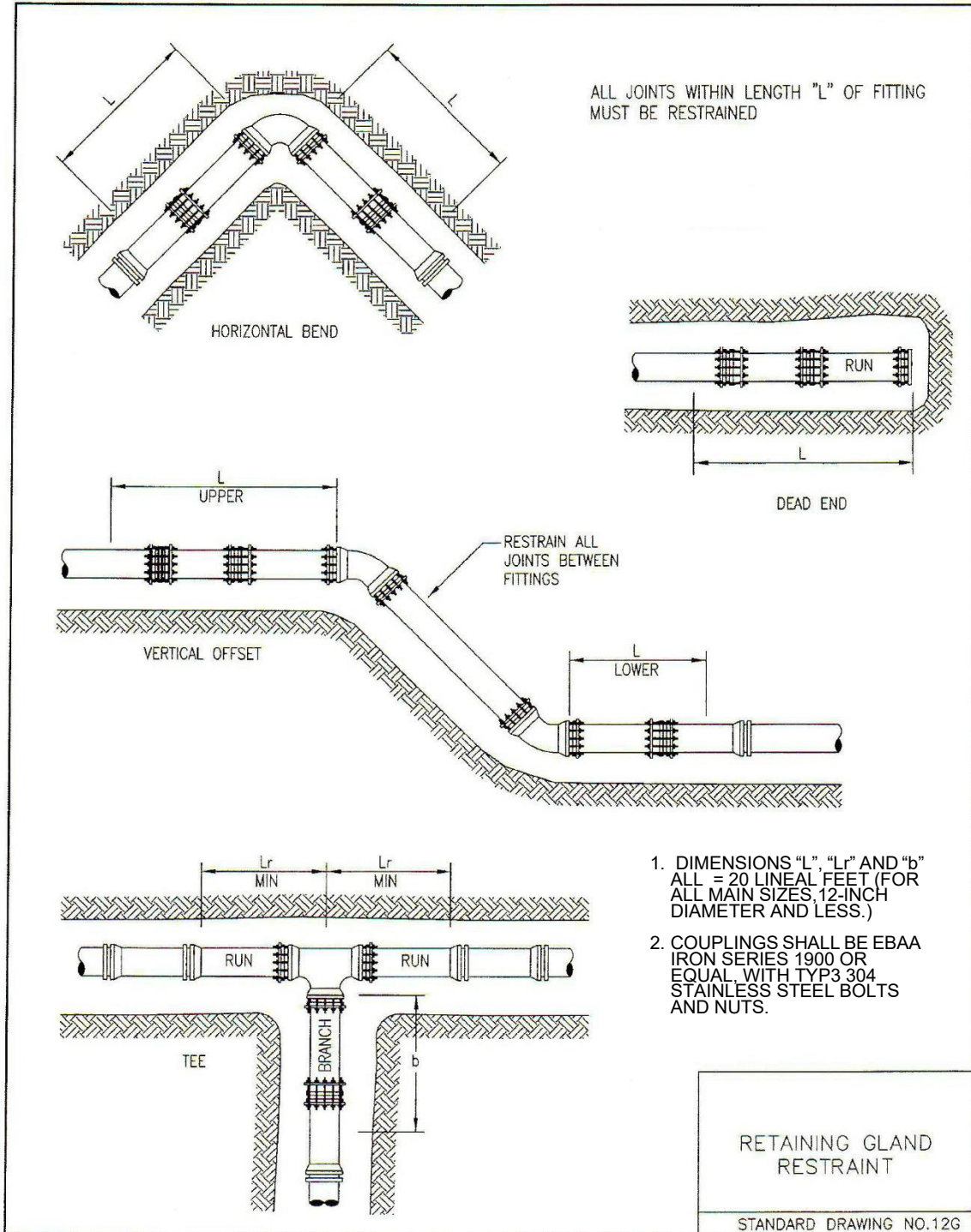

APPENDIX

Detail J—Recommended Scope of Work for Professional Services
Organizations

Request for Statement of Qualifications

To enter into a

Public – Private Partnership

For the

Operation, Maintenance and Management

of the

Sangamon Valley Public Water District Water

and Wastewater Treatment Works

TABLE OF CONTENTS

<u>SECTION</u>		<u>PAGE</u>
I.	GENERAL BACKGROUND.....	1
II.	PUBLIC-PRIVATE PARTNERSHIP PURPOSE AND OBJECTIVE.....	1
III.	REQUIRED STANDARDS	1
IV.	GENERAL INFORMATION.....	3
	ADDITIONAL QUALIFICATIONS INFORMATION	3
V.	PRE-SUBMISSION CONFERENCE, FACILITY EVALUATIONS AND OTHER PROCUREMENT INFORMATION.....	4
VI.	EQUIPMENT OWNED BY THE SVPWD	5
VII.	SUBMITTAL FORMAT AND CONTENT.....	5
VIII.	SCHEDULE OF EVENTS	10
IX.	SCORING OF SUBMITTALS.....	11
X.	ADDITIONS AND EXCLUSIONS	14
XI.	NEGOTIATIONS WITH HIGHEST SCORING RESPONDENT.....	15

I. GENERAL BACKGROUND

The Sangamon Valley Public Water District (SVPWD) is requesting Statements of Qualifications (SOQ) from respondents capable of entering into a public-private “partnership” agreement to provide operation, maintenance, and management services for the SVPWD’s Water and Wastewater Treatment Works. The SVPWD is interested in maximizing benefits for its citizens from this effort and views the intended relationship as a partnering venture in which issues are quickly and fairly resolved to the mutual benefit of the SVPWD, its rate payers and the successful respondent. The SVPWD and the successful respondent shall enter into a mutually binding operation, maintenance and management agreement addressing the topics contained in this document. This agreement shall not constitute a legal partnership. The SVPWD therefore reserves the right to expand the scope of services to include additional responsibilities.

It is understood that the information contained in the SOQ and the experience, guarantees and innovative approaches demonstrated therein shall be the general basis for selection of a respondent to provide these professional services. The SVPWD expects to select the highest scoring respondent based on a structured point scoring evaluation. The scoring evaluation (Section IX) shall consider each respondent’s ability to perform the required services, experience and technical expertise, ability to make financial and technical guarantees, corporate resources and depth, and innovative approaches. The SVPWD will immediately begin negotiations with the selected highest scoring respondent. Should the negotiations fail to result in an executed agreement, the SVPWD may elect to terminate negotiations with the first-ranked respondent and begin negotiations with the second-ranked respondent, and so on, or cancel the process.

II. PUBLIC PRIVATE PARTNERSHIP PURPOSE AND OBJECTIVE

The purpose of this partnership is to operate, maintain and manage the SVPWD’s water/wastewater treatment facilities more cost effectively and efficiently. The objective is to assure uninterrupted continuous water and wastewater services to our customers, provide the highest level of asset management to attain the most cost-effective operations and maintenance, assure all operations remain in strict compliance with regulatory permits and regulations, consider innovations to lower the capital and operating costs of any and all aspects of operations and continue local purchases of supplies, consumables and services, wherever practical.

III. REQUIRED STANDARDS

This section establishes standards of experience and financial capability that the SVPWD requires for a respondent to be considered qualified. The SVPWD, in its sole discretion, will decide if a respondent meets the standards. Please note respondent is the entity responding to this solicitation and not parent company, joint ventures partners or other corporate affiliates. Scoring of the qualified respondents will be as described in Section IX.

Respondent must:

1. Have been in business of providing full services public-private partnership agreements for operation, maintenance and management of water and wastewater treatment facilities for at least five (5) years. Full-service public-private partnership contracts for operation, maintenance and management means, at a minimum, providing all labor and management, paying all operation and maintenance expenses, guaranteeing a maximum cost and guaranteeing performance including regulatory agency compliance. Full-service contract operation, maintenance and management (OM&M) does not include consulting contracts or contracts for the management of a portion of a treatment facility (i.e.

- maintenance, sludge removal or sludge dewatering).
2. Operate five (5) or more water and/or wastewater treatment facilities of at least five (5) MGD design capacity. All facilities shall be located in the United States and its possessions and shall be under U.S. EPA and appropriate state environmental regulatory agency jurisdiction.
 3. Operate at least one water treatment facility with a design average flow of at least five (5) MGD and at least one wastewater treatment facility with a design average flow of at least fifteen (15) MGD. All facilities shall be located in the United States and its possessions and shall be under U.S. EPA and appropriate state environmental regulatory agency jurisdiction.
 4. Furnish liability and property damage insurance of not less than \$3,000,000 combined single limits for bodily and/or property damage. Proof of coverage must be provided.
 5. Respondent shall submit evidence of bonding capability in the annual contract amount. The amount of the bond may be reduced depending upon the final scope of services.
 6. Have demonstrated successful experience in transitioning public sector employees into the private sector. Cite specific examples of such experience and provide references.
 7. Have specific experience providing full-service operation, maintenance and management services for iron removal with softening (Kurita – 1000 gpm) treatment facilities. Provide all facilities where respondent provides full-service operation, maintenance, and management services for tertiary treatment facilities. List locations, client, size, and length of service.

IV. GENERAL INFORMATION

Each respondent must respond to each of the following requests/questions in a clear and comprehensive manner. Failure to do so may result in disqualification.

1. Provide the full name, tax identification number and main office address of the responding entity (hereinafter referred to as the "respondent") which would ultimately enter into a contract with the SVPWD.
Note: Respondent information is to be submitted for the respondent and not parent company, joint venture partners or other corporate affiliates.
2. Identify when the respondent was organized and, if a corporation, where incorporated and how many years engaged in providing contract operations, maintenance and management services under that name.
3. A description of the circumstances, if any, related to any council person or other officer, employee, or person who is payable in whole or in part from the SVPWD that has or had any direct or indirect personal interest in the respondent.
4. Identification of the firms that the respondent intends to subcontract or otherwise use to perform work on this project.

ADDITIONAL QUALIFICATIONS INFORMATION

1. Provide a listing of all full-service public-private partnership arrangements for the operation, maintenance and management of water and wastewater facilities (systems) which the respondent currently has, including the gross annual amount of each partnership; the partnership start date; the anticipated completion date; the name, address, contact person and telephone number of the owner; and the size and type of facility. Full-service public-private partnerships for the operation, maintenance and management means, at a minimum, providing all labor and management, paying all operations and maintenance expenses, guaranteeing a maximum cost, and guaranteeing

- performance including regulatory agency compliance.
2. Describe the respondent's specific and relevant experience related to the scope of services requested herein; specifically, the size of facilities, type of facilities, technology, etc.
 3. Describe respondent's depth and resources which would also be available for the benefit of the SVPWD.
 4. Demonstration of experience in capital planning aspects of water and/or wastewater systems. Identify specific projects where such services are provided and the results of such service.
 5. Have specific experience that respondent possesses to evaluate, recommend and implement corrective actions to reduce infiltration/inflow into the wastewater collection and conveyance system.
 6. Have the proven ability to successfully deal with odor issues which may typically be found at wastewater treatment facilities.

V. PRE-SUBMISSION CONFERENCE, FACILITY EVALUATIONS AND OTHER PROCUREMENT INFORMATION

The SVPWD will conduct a **mandatory** pre-submission conference and tour of the facilities on March 10, 2023 to begin at 9:00 a.m. at the main water treatment facility, located at 709 N Prairie View Rd, Mahomet, IL 61853.

The purpose of the pre-submission meeting is to answer questions regarding the Statement of Qualifications (SOQ). All respondents interested in submitting an SOQ should contact Kerry Gifford (217-841-1056) no later than Tuesday, March 7, 2023, to indicate their intent to attend the pre-submission conference. Each interested respondent should ensure that they meet or exceed the Required Standards set forth in Section III of this document.

The SVPWD will make available on the day of the tour sufficient information to submit a SOQ including construction plans and specifications, design reports, NPDES compliance reports, operating budgets and other pertinent data. Most material will be included on a thumb drive available to the respondents. SVPWD will not have copying services available to respondents, digital photography will be allowed. SVPWD will make the electronic information packet available to all respondents.

Questions must be received at least 5 days prior to the SOQ due date. Copies of all questions and answers, and any addenda to supplement the SOQ, will be sent to each respondent no later than three days prior to the SOQ due date. Only formal written responses to properly submitted questions will be binding. All questions, requests for information, discrepancies, etc. should be submitted to Kerry Gifford in writing by email (kgifford@svpwd.com) no later than Monday March 13, 2023.

Contact with other SVPWD officials is prohibited and can be considered as grounds for disqualification from the selection process.

The SVPWD reserves the right to request additional data or information after the submittal date, if such data or information is considered pertinent, in the SVPWD's sole view, to aid the review and evaluation process.

The SVPWD reserves the right to supplement, add to, delete from and change this solicitation document.

The SVPWD reserves the right to reject any portion of any submittal and/or reject all submittals, to waive any informalities or irregularities in the submittals, or to re-advertise.

VI. EQUIPMENT OWNED BY THE SVPWD

All land, buildings, improvements and permanent equipment which are presently in place, or new facilities which may be added by the construction projects, shall remain or become the property of the SVPWD. Should the respondent fund any facility improvement at the request and with the approval of the SVPWD, such facilities shall become the SVPWD's after the completion of a repayment schedule. All existing facilities shall be made available to the respondent for its use in providing the services under the partnership agreement.

Expendable supplies and spare parts which are on hand on the date of the initiation of the partnership shall be inventoried. The respondent shall assume responsibility for such inventory and at the end of the partnership period, the inventories shall be returned to the SVPWD at a value equal to the beginning value, less normal wear and tear.

The respondent shall maintain all land, buildings, improvements, vehicles and permanent equipment that are within the scope of the partnership agreement. Equipment and vehicle maintenance shall be performed by the respondent in accordance with manufacturer's recommendations or good industry practices and the respondent will be required to provide proof thereof to the satisfaction of the SVPWD. Separately, the SVPWD and the respondent may arrange for the respondent to purchase, maintain, and replace the rolling stock and transportable equipment currently in use by the SVPWD. Such purchase prices shall have buy-back provisions to enable the SVPWD, upon partnership completion or early termination, to buy back the same or similar inventory.

VII. SUBMITTAL FORMAT AND CONTENT

The SOQs must contain at least the following:

- Transmittal Letter
- Required Standards
- General Information
- Additional Qualifications Information
- Operating Plan
- Business Considerations
- Draft OM&M Agreement

The SOQ shall identify any and all non-monetary terms and conditions associated with the services included in the SOQ, such as the respondent's limitations on liability. After selection of the highest scoring respondent, the scope of work shall be clarified, any changes shall be negotiated along with the Agreement, beginning with the draft agreement submitted in the SOQ.

Following are further discussions relative to the content of each of the suggested chapters of the SOQ. Transmittal Letter to include at a minimum, a commitment by respondent, if selected, to enter into good faith negotiations. Letter must be signed by an officer of the respondent firm.

Required Standards - Responses to requests contained in Section III of this document.

General Information - Responses to requests contained in Section IV.

Additional Qualifications Information - Responses to requests contained in Section IV of this document.

Operating Plan — The Operating Plan should discuss the following topics:

- a. Provide a listing of the specific individuals assigned to the Management Team and to Technical Support that the respondent will assign to this partnership during the transition and operation, and provide the background and experience of those individuals.
- b. Provide a detailed staffing plan indicating the type and quantity of the various positions the respondent feels is necessary to provide the services requested.
- c. Discuss the transition procedure and the impact of any surplus employees and the

- respondent's plan to accommodate them.
- d. Provide an operating plan for the facilities and other responsibilities that indicate how the respondent will provide operation, maintenance and management services.
 - e. Provide description of any enhancements the respondent will make in operations and maintenance of the SVPWD's facilities.
 - f. Specifically identify any additional services that exceed the services requested herein.
 - g. Changes or limitations to the general provisions listed in Section VII, draft partnership agreement.

Business Approach — Discuss respondent's position on such business issues as assumption of risk, future years' price adjustments, repair and replacement, capital improvements and guarantees.

Draft OM&M Contract - Include a draft OM&M agreement for the SVPWD to review.

The SVPWD is requesting a draft OM&M agreement as a part of the SOQ. However, a summary of some of the general provisions the SVPWD will expect to see in any final OM&M agreement are as follows:

- Provision of liability for the payment of fines and/or civil penalties levied against the respondent and/or the SVPWD by any regulatory agency having jurisdiction, as a result of failure to comply with the terms and conditions of any duly authorized permit, court order, administrative order, law, statute, ordinance, etc. for reasons resulting from the respondent's negligence during the period of the partnership.
- Provisions for compliance with all applicable law and regulations regarding the operation, maintenance and management of the facilities (systems) and reporting requirements and a process control system which furnishes complete and accurate records. System should be capable of readily providing historical data and trends.
- Provision of indemnification and hold harmless of the SVPWD and its agents, officers, assigns, employees, etc. from any loss or liability for claims, damages (excluding consequential, special and/or incidental damages), lawsuits for reasons resulting from the respondent's negligence during the period of the partnership. To the extent respondent seeks to monetarily limit such indemnification, the respondent should clearly indicate the proposed amount of any such limitation.
- Provision of comprehensive liability insurance policies including the SVPWD as an additional insured for bodily injury and/or property damage in an amount of not less than three million dollars (\$3,000,000); a certificate of such insurance shall be submitted to the SVPWD upon signing of the agreement.
- Provision of a fixed dollar value for Repair and Replacement such that the respondent's obligations will be explicit as to maintenance of the SVPWD's equipment and facilities. Such Repair and Replacement limit will not include respondent's normal on-site labor. A specific method of decision making concerning the use of funds for repair and replacement should be outlined.
- Provision that the respondent shall be responsible for maintaining all manufacturer's warranties on new equipment purchased by the SVPWD and assist the SVPWD in enforcing existing equipment warranties and guarantees.

- Provision that the respondent shall provide certified qualified personnel in sufficient numbers to provide effective and efficient operations, maintenance, administration and management to meet relevant legal requirements and certifications regarding operation and maintenance and are capable and demonstrate experience necessary to operate and maintain the facility(s).
- Provisions to offer available positions to present full-time employees and provide comparable total wages and benefits packages.
- Provision that the respondent shall operate all facilities such that odor and noise shall be effectively controlled and that no avoidable disruption of adjacent neighborhoods shall result.
- Provision that the respondent shall operate the facilities such that they are fully staffed Monday through Friday for eight (8) hours a day, with night and weekend work only when necessary. Respondent shall monitor the facilities twenty-four (24) hours per day, seven (7) days per week.
- Provision that the respondent shall provide training for personnel in areas of operation, maintenance, safety, supervisory skills, laboratory, energy management, etc. A proper safety program must be implemented that includes training, documentation, certification, and mandatory compliance with all portions of that program.
- Provision that the respondent shall provide the SVPWD with full documentation that maintenance is being performed on all SVPWD owned equipment in accordance with manufacturer's recommendations at intervals and in sufficient detail as may be determined by the SVPWD. Such a maintenance program must include documentation of maintenance and a spare parts inventory.
- Provision that within the first ninety (90) days, the respondent shall provide the SVPWD with a listing of any recommended capital improvements the respondent believes will be required for any of the facilities covered under the partnership. The respondent will not be relieved of his responsibility to perform up to the capabilities of the existing facilities if the recommendations are not implemented, however.
- Provision for the respondent to provide computerized maintenance, process control and laboratory management systems.
- Provision for the term of the agreement between the SVPWD and the respondent be five (5) years with the mechanism(s) or alternatives to the annual price adjustments to be described by the respondent.
- Provision for the SVPWD and respondent to negotiate an increase or decrease in the annual price in the event any legal or regulatory requirement changes occur in project operation, reporting requirements, monitoring requirements, level of treatment required, personnel qualifications or staffing required by any governmental agency having jurisdiction over such changes. The adjustment approach alternatives shall be described by the respondent.

- Provision that the respondent shall arrange financing and make arrangements for the provision of providing for the design and construction/installation of capital improvements as requested and approved by the SVPWD, subject to mutually agreeable terms and conditions.
- Provision for agreement termination if the level of performance is unsatisfactory.
- Provision that the respondent shall be responsible for sludge management and disposal. Methods and costs of sludge management and disposal shall be approved by the SVPWD and the SVPWD shall pay for such costs.
- Provision that the respondent shall be responsible for regulatory compliance as long as the (influent/raw water) meets the quantity/quality parameters identified in the agreement. Respondent's performance in this regard shall be excused for uncontrollable circumstances.
- Provision which specifies that neither party shall be liable to the other for special, incidental, or consequential damages.

VIII. SCHEDULE OF EVENTS

Each respondent must submit five (5) copies of the SOQ no later than 2:00 P.M. on Friday March 17, 2023, addressed to:

Meghan Hennesy, Board Chair
 Sangamon Valley Public Water District
 709 N Prairie View Rd.
 Mahomet, IL 61853

The outside of the shipping carton must be clearly marked:

"STATEMENT OF QUALIFICATIONS — PUBLIC-PRIVATE PARTNERSHIP FOR THE OPERATION, MAINTENANCE AND MANAGEMENT OF THE TREATMENT WORKS FOR THE SVPWD"

Schedule

<u>Item</u>	<u>Date</u>
Advertisement for SOQ	2/28/23
Pre-submission meeting (mandatory)	3/10/23
Site tours	3/10/23
SOQ submittal	3/17/23
Respondent interviews (if required)	3/20/23
Selection of highest rated respondent	3/24/23
Negotiations	3/27/23 – 3/31/23
Agreement execution	4/7/23
Commencement of services	4/19/23

IX. SCORING OF SUBMITTALS

The evaluation of the SOQ and of the respondents presenting them will be carried out by an Evaluation Board ("Board") created for this purpose. The Board will make its decision based on information

gathered during the procurement process and evaluation criteria outlined in this section. Failure to provide relevant information may result in penalties being assessed on the evaluation score.

Respondents will be evaluated as follows:

1. Board members will individually evaluate each SOQ on the points system identified in Table 1.
2. The Board will meet to discuss the SOQ's and evaluate scores. Consensus will be reached with the Board agreeing to scores representative of the Board's overall evaluations. If consensus cannot be reached, the scores will be averaged and these scores will represent the Board's overall evaluation to that point.
3. Respondents may be further evaluated based on an oral interview with the Board members. The purpose of this interview is to clarify the qualifications of the respondents and allow the Board to verify its evaluation. Additional services or significant changes to the submittals shall be identified separately, as required elsewhere in this SOQ.
4. The respondents will be notified of the ranking after recommendation for selection has been made to SVPWD Council.

The SOQ evaluation matrix outlined in Table I will be used to address the following criteria:

- Qualifications to operate, maintain and manage the facilities (systems) and provide services based on previous experience, management capability, technical resources and financial capability.
- Record of operating facilities and providing services for facilities (systems) of similar size and complexity. Visits to sites and/or contact with municipalities presently being served will be made if thought to be necessary to complete the evaluation.
- The qualifications of the personnel being proposed to manage and support the facilities (systems) in terms of expertise and experience with similar facilities (systems) and services.
- The quality of the submittal in terms of technical correctness and presentation.
- The respondent's responsiveness to the SOQ.
- The methodology to deal appropriately with the transition from SVPWD operations to respondent operations, the method of staffing the facilities and approach to managing excess employees.
- The maintenance program that will be undertaken to ensure the capital investment in existing and future facilities the SVPWD has made is properly maintained and proof of condition and trends are sufficiently documented.
- The performance guarantees that are proposed.
- The adequacy and completeness of answers to the questions in Sections III and IV.
- The adequacy of the operating plan
- The draft OM&M agreement
- Business approach

Table I
EVALUATION MATRIX - - STATEMENT OF QUALIFICATIONS

<u>Criteria</u>	<u>Maximum Points</u>	<u>Points Scored</u>
1. Respondent Profile <ul style="list-style-type: none"> • General capabilities • Financial capability • Bonding capability • Proof of insurance • Years in business • Commitment to public-private partnership for operation, maintenance and management • Management experience and depth • Operations and specialist support services 	10	_____
2. Respondent Experience <ul style="list-style-type: none"> • Number and size of projects • Number of projects of similar size and complexity • Number of employees directly involved in projects • Years of experience • \$ value of projects • Corporate depth and resources • Other relevant experience 	15	_____
3. Operating Plan <ul style="list-style-type: none"> • Technical understanding • Transition plan • Transition experience • Operating, maintenance and management approach • Creativity: <ul style="list-style-type: none"> — Innovation — Operating/maintenance changes • Clarity of presentation of services to be provided 	25	_____
4. Personnel Assigned to this Project <ul style="list-style-type: none"> • Home office management involved and role throughout project • Staffing plan • Organization chart, reporting, etc. • Staff qualifications and experience 	10	_____
5. Draft OM&M Agreement <ul style="list-style-type: none"> • Meets all general provisions of Section VII, Draft OM&M Agreement • Fair and equitable price adjustment formula 	10	_____
TOTAL	70	_____

Selection of a respondent to perform these professional services will be based upon qualifications, experience, historical performance record, financial capability, understanding of needs, suggestions for improvements, suggested innovations and the respondent's proven technical capabilities. In addition to the data and documentation being submitted by the respondent in response to this request, the SVPWD reserves the right to make an on-site inspection and evaluation of any facility at which operation, maintenance and management services are currently being performed by the respondent. If the SVPWD chooses to exercise this right, the respondent shall provide a representative, with or without notice, to accompany the SVPWD or its delegated representatives on any on-site inspection. The inspection is not limited to only one facility. All costs for transportation and subsistence to inspect any facilities incurred by SVPWD personnel shall be borne by the SVPWD.

X. ADDITIONS AND EXCLUSIONS

It is understood that the SVPWD has specified the SOQ's to be provided. All other additions and/or any exclusions shall be clearly and separately identified as noted herein. Non-compliance with this requirement will be considered cause for disqualification of the respondent from further consideration.

XI. NEGOTIATIONS WITH HIGHEST SCORING RESPONDENT

The SVPWD regards the submission of the SOQ as the most important factor in selection of a respondent to provide services for the operation, maintenance and management of the water and wastewater facilities (systems) under a public-private partnership. The SVPWD reserves the right to reject any and all SOQ's and is under no obligation to award a partnership.

The SVPWD intends to negotiate an agreement with the respondent with the highest score, as determined by the Board. However, should the negotiation with the highest scoring respondent not produce an acceptable partnership arrangement, the SVPWD will request the respondent placing second in the evaluation process to begin negotiations.

The responsibility for the final selection and partnership negotiation rests solely with the SVPWD. The SVPWD shall not be liable to any respondent for costs associated with responding to the SOQ for the respondent's participation in any oral interview, or for any costs associated with negotiations.

END OF ORDINANCE